

This issue of LEA  
is a co-publication of

**LEONARDO**<sup>®</sup>  
THE INTERNATIONAL SOCIETY FOR THE  
ARTS, SCIENCES AND TECHNOLOGY

Sabancı  
Üniversitesi

**KASA  
GALERİ**

**Goldsmiths**  
UNIVERSITY OF LONDON

**L**eo

**E-SCAPES**

**ARTISTIC EXPLORATIONS OF NATURE AND SCIENCE**

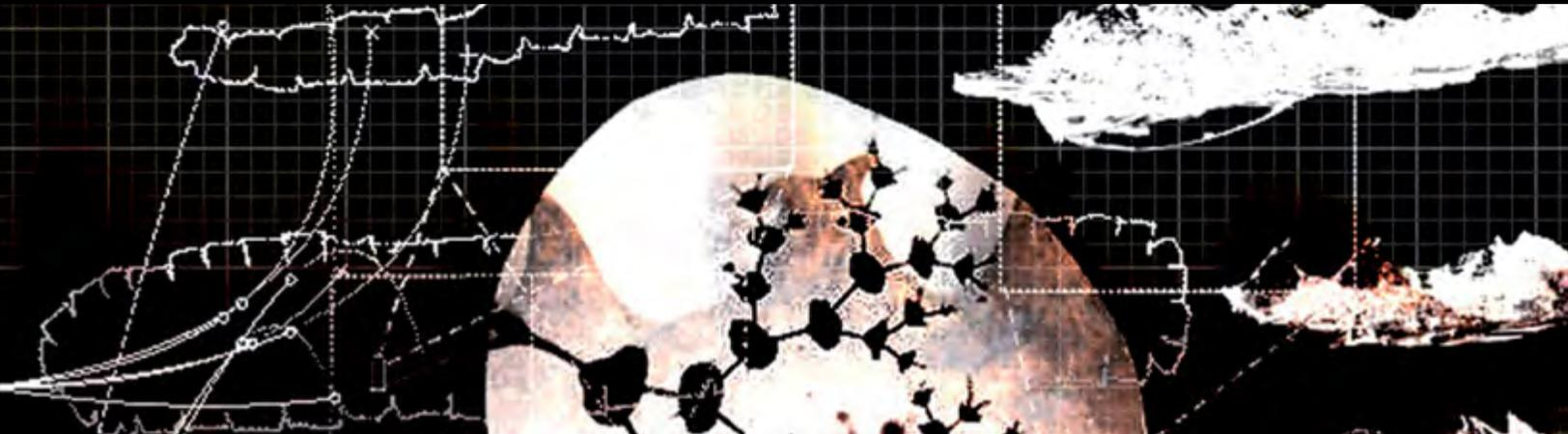

This issue of LEA  
is a co-publication of

**LEONARDO**<sup>®</sup>  
THE INTERNATIONAL SOCIETY FOR THE  
ARTS, SCIENCES AND TECHNOLOGY

Sabancı  
Universitesi

KASA  
GALERİ

**Goldsmiths**  
UNIVERSITY OF LONDON

Copyright © 2012 ISAST

**LEA PUBLISHING & SUBSCRIPTION INFORMATION**

**EDITOR IN CHIEF** Lanfranco Aceti

**CO-EDITOR** Özden Şahin

**MANAGING EDITOR** John Francescutti

**SENIOR CURATORS & SENIOR EDITORS** Lanfranco Aceti and Christiane Paul

**EDITOR & CURATOR** Vince Dziekan

**KASA GALLERY VICE DIRECTOR AND IN-HOUSE CURATOR** Özden Şahin

**ART DIRECTOR** Deniz Cem Önduygu

**GRAPHIC DESIGNER** Zeynep Özel

**EMAIL**

info@lealmanac.org

**WEB**

- » [www.vimeo.com/leagallery](http://www.vimeo.com/leagallery)
- » [www.lealmanac.org](http://www.lealmanac.org)
- » [www.twitter.com/LEA\\_twitts](http://www.twitter.com/LEA_twitts)
- » [www.flickr.com/photos/lea\\_gallery](http://www.flickr.com/photos/lea_gallery)
- » [www.facebook.com/pages/Leonardo-Electronic-Almanac/209156896252](http://www.facebook.com/pages/Leonardo-Electronic-Almanac/209156896252)
- » [kasagaleri.sabanciuniv.edu](http://kasagaleri.sabanciuniv.edu)

Copyright 2011 ISAST

Leonardo Electronic Almanac is published by:

Leonardo/ISAST  
211 Sutter Street, suite 501  
San Francisco, CA 94108  
USA

Leonardo Electronic Almanac (LEA) is a project of Leonardo/The International Society for the Arts, Sciences and Technology. For more information about Leonardo/ISAST's publications and programs, see [www.leonardo.info](http://www.leonardo.info) or contact [isast@leonardo.info](mailto:isast@leonardo.info).

Reposting of this journal is prohibited without permission of Leonardo/ISAST, except for the posting of news and events listings which have been independently received.

Leonardo is a trademark of ISAST registered in the U.S. Patent and Trademark Offices.

All rights to the content of this issue reserved by Leonardo/ISAST and the copyright holders.

# Contents

- Lanfranco Aceti* **06** Introduction: The Physical and Virtual Structures of the Landscapes of Contemporary Art
- Lanfranco Aceti* **08** Explorations, Structures, Observations, Analyses, Canons: Who Can Say That Contemporary Art Is All About Unchecked Freedoms?
- Vince Dziekan* **14** The World Needs Forms
- Jane Prophet* **16** "Explorations of Structure"
- 44** Interview with Jane Prophet, "Explorations of Structure"
- Paul Catanese* **48** "Visible From Space"
- 58** Interview with Paul Catanese, "Visible From Space"
- 68** Kasa Gallery Tri-fold Brochure
- 70** Kasa Gallery Exhibition Documentation

# Introduction: The Physical and Virtual Structures of the Landscapes of Contemporary Art

As the Editor in Chief of the Leonardo Electronic Almanac (LEA) I am pleased to present our first catalog born from a collaboration between LEA, Sabanci University, Kasa Gallery and Goldsmiths, University of London. It's been almost two years since LEA's digital media exhibition platform began, thanks to the hard work of Vince Dziekan and Özden Şahin.

We are thrilled with the reception that the LEA Digital Platform has received. We are thankful for such a large participation that proves that there is an audience interested in being part of contemporary artistic development within the field of art, science and technology.

The LEA Digital Platform has pioneered a space of rigorous curatorship within social media such as Twitter, Facebook and Flickr that appeared to be conceived more for spontaneous and casual interactions than the formal display of images. Our major curatorial challenge was that of using these media for dissemination and presentation while at the same time retaining some of the more rigorous structures of a museum display.

The strategy that has paid off for LEA and its online exhibition platform was to not solely engage with the artworks and the artists in a limited process of display and dissemination but to consider the social media platform as merely one stage in a larger exhibition process – a fluxus methodology applied to curating in order to revel in, as well as take advantage of, the fluidity of contemporary social networks.

It had always been my intention of actually 'making' in a physical

space the exhibitions that we were showing online. The partnership with Kasa Gallery, of which I am the Director and supported by Sabanci University, has provided the physical space in Istanbul from which selected shows can premiere before traveling to other galleries around the world.

In this process, both LEA and Kasa Gallery foster international collaborations in the fine arts with partners like Mike Stubbs at FACT, Janis Jefferies at Goldsmiths, Peter Ride at Westminster University, Richard Rinehart at the Samek Art Gallery and Christiane Paul at the New School.

These are just a few of the people that LEA is now working with, while we continue announcing and growing our 2012 program of digital media exhibitions.

Operating across LEA's social media platforms these online exhibitions have become part of the LEA web archives as well as the background to our exhibitions in the physical space of Kasa Gallery and other international galleries and museums.

Encouraging a playful and expansive mode of discourse, the adopted format provides artists with the opportunity to devise, recreate or represent a portfolio of artworks, processes or ideas sequentially over a month-long series of images or 'frames.'

Our inaugural season was launched in the autumn of 2010 and featured projects by Paul Catanese and Jane Prophet, to whom I

am most grateful for their patience and support in this process.

Paul Catanese inaugurated the LEA Online Exhibition Platform with his exhibition *Visible from Space* in September 2010. The show was designed as a series of 'digital artworks and sketches,' almost an artist's diary and impression of the world as seen from space. Issues related to the landscape, its representation and political structure, mixed with the poetics of its visuality, were combined in an enticing sequence of images. Research and development for *Visible from Space* was supported by a month-long residency in June 2010 at the Goldwell Open Air Museum, located just outside Death Valley.

Together with Paul Catanese, the online exhibition *Explorations of Structure* by Jane Prophet (originally released in October 2010) is being installed in Kasa Gallery, while I am writing this introduction. In her portfolio of images, Jane Prophet takes previously completed artworks and re-evaluates them as explorations of structure. Prophet uses innovative media combined with traditional aesthetics to address issues related to the use of scientific methods and technologies in creating art. This can be seen in her use of elements derived from fractal mathematics to the treatment of politics of landscape. She demonstrates through her works, which exist in a variety of forms, the ability to fascinate the audience with innovative aesthetics.

Both online exhibitions and this catalog are accompanied by interviews with the artists by myself and Vince Dziekan.

This is the first catalog to signal LEA's renewed activity and presence on the international art world at the intersection of art, science and technology. There are many people to whom I have to say thanks: Vince Dziekan, for his curatorial work; Özden Şahin, who has worked with me and supported me with LEA's and Kasa Gallery's relaunch;

and, last but not least, Christiane Paul who has believed in LEA's relaunch project since its beginnings.

It is my hope that LEA will continue to foster the integration of the physical experience of artworks with virtual online exhibitions that, by disseminating artworks through social media platforms, contribute to raising awareness and reshaping the visual aesthetics of the XXI century by finding new ways for engagement and participation.

Lanfranco Aceti  
LEA Editor in Chief  
Kasa Gallery, Director



The Jane Prophet exhibition can be followed online:  
Facebook: <http://ow.ly/2WiNR>  
Flickr: <http://ow.ly/2WiPw>  
Twitter: <http://ow.ly/2WiQM>

The Paul Catanese exhibition can be followed online:  
Facebook: <http://on.fb.me/xVZiW7>  
Flickr: <http://bit.ly/AuKbdw>  
Twitter: <http://ow.ly/2WiQM>

# EXPLORATIONS, STRUCTURES, OBSERVATIONS, ANALYSES, CANONS: WHO CAN SAY THAT CONTEMPORARY ART IS ALL ABOUT UNCHECKED FREEDOMS?

by

Lanfranco Aceti

Istanbul, January 08, 2012

## ABSTRACT

The article will analyze the artistic practice of two artists –Jane Prophet and Paul Catanese– within the context of contemporary art at the intersection of new media, science and technology.

The construct that contemporary art is all about unchecked creativity and freedom is an inheritance of romantic ideas that are inspired by the ‘genius’ of creation and are based on the rejection of previous centuries’ aesthetic forms, structures and skills. By retracing the concept of Genius to Kant it is possible to see that in the philosopher’s analysis of the relationship between art and genius, the latter is able to create art because of the **rules** bestowed upon him by Nature.<sup>1</sup>

The current “ideological aesthetic conflict”<sup>2</sup> between David Hockney and Damien Hirst on the modalities of production is a reflection of two opposite approaches where one focuses on skills formed

through canons, structures, observation and repetitions while the other adopts forms of production in the construction of the poetic that are based on post industrial relationships –the artworks are physically done by someone else and the artist limits his contribution to selection and branding of the chosen pieces with his signature.

The exhibition *E-scapes: Artistic Explorations of Nature and Science* at Kasa Gallery, Istanbul, co-curated by myself and Vince Dziekan, presents the work of Prophet and Catanese in this larger context and analyzes two different approaches that are rooted in an artistic practice that reflects canons, methodologies and approaches typical of skill based aesthetics.

## KEYWORDS

Curating, contemporary art, new media art, explorations, structures, observations, analyses, canons  
*E-scapes: Artistic Explorations of Nature and Science* is an exhibition

in the physical space of Kasa Gallery that remediates two previous exhibitions that took place in the online exhibition platform of the Leonardo Electronic Almanac in 2010.

Paul Catanese inaugurated the LEA Online Exhibition Platform with his exhibition *Visible from Space* in September 2010. The show was designed as a series of ‘digital artworks and sketches,’ almost an artist’s diary and impression of the world seen from space. Issues related to the landscape, its representation and political structure, mixed with the poetics of its visuality were combined in an enticing sequence of images. Research and development for *Visible from Space* was supported by a month-long residency in June 2010 at the Goldwell Open Air Museum, located outside of Death Valley.

The online exhibition *Explorations of Structure* by Jane Prophet (originally released in October 2010) was conceived in its curatorial remit as a contrasting view to the work of Paul Catanese. In her portfolio of images, Jane Prophet took previously completed art works and re-evaluated them as explorations of structure. Prophet uses innovative media combined with traditional aesthetics to address issues related to the use of scientific methods and technologies in creating art. This can be seen in her use of elements derived from fractal mathematics to the treatment of politics of landscape. She demonstrates through her works, which exist in a variety of forms and contexts, the ability to fascinate the audience with innovative aesthetics.

The process to set up the exhibition in the physical space of Kasa Gallery has provided the opportunity to further reflect on the nature

of the artworks and the creative process of the artists. It still surprises me that many of my students believe that no relation exists between conceptual underpinning, historical references, innovation, originality, skills and the production of the artwork.

The work of both Paul Catanese and Jane Prophet being at the intersection of art, science and technology (and technology is perceived by many of my students as new media technology: e.g. smart phones and tablets, nothing older than ten years) should have been immediate and unmediated. The expectation would be that of an instantaneous production with no research and for immediate gratification.

The reality is that *E-scapes: Artistic Explorations of Nature and Science* is an hymn to canons, observation (both scientific and aesthetic), explorations, structures and rules. In my curatorial analysis to justify the artist’s right to complexity and research I looked at the writing of Gerald James Holton’s *The Advancement of Science, and Its Burdens* and Henry Margenau’s *Open Vistas*.

Holton writes about Einstein and the complex relationship that the scientist had with methodological research, observation and analysis. Faced with the difficulty of constructing theories that could be exactly formulated Einstein, as well as Holton, seek a “judgement into which esthetic considerations and other preferences can enter prominently.”<sup>3</sup>

Holton’s analysis of Einstein’s methodology is not a rejection of observation, analysis, rule and structure, but more of a statement

in defense of the complexity of scientific analysis and its theoretical formulation. The idea of absolute freedom where 'esthetic considerations and other preferences' can feature prominently is one that is alien to scientific thought and was, in many ways, alien to aesthetic thinking as well. Until the construct that contemporary art is all about unchecked creativity took hold. The concept of absolute artistic freedom from knowledge and rules was inherited by a romantic perception of the creative genius, reinforced by the rebellion of the futurists and consolidated through the postmodern models of factory production (Andy Warhol) and corporate branding (Damien Hirst).

But if we consider the concept of 'genius' as one of a creator that ignores the knowledge of past forms, structures and skills, is this a structure –because even absolute freedom is an operational structure and strategy– that can provide a response to the questions of artistic knowledge and its methodologies?

My aesthetic and philosophical doubts remain. They remain because if the idea of Genius can be traced back to Immanuel Kant the philosopher's construction is very complex. Kant in his analysis of the relationship between art and Genius writes that the latter is able to create art because of the **rule** given to him by Nature.

"The rest of the section argues for the necessity of presupposing a rule for something to be art, and then concludes that it must be 'nature in the individual (and by virtue of the harmony of his faculties)' that is responsible for giving the rule to art –which comes to saying that "fine art is only possible as a product of genius." <sup>4</sup>

Therefore if fine art is only a realization of the Genius and the Genius receives the rule to make art by Nature, it follows that the

Genius is able to create solely because of the **rule** bestowed onto him by nature.

While I am writing this piece David Hockney has delivered a critique of artists who have no craft, who delegate the making. A poster for his new major solo exhibition at the Royal Academy reads, "All the works here were made by the artist himself, personally." A dig at Damien Hirst? He nods. "It's a little insulting to craftsmen, skillful craftsmen... I used to point out at art school, you can teach the craft, it's the poetry you can't teach. But now they try to teach the poetry and not the craft." <sup>5</sup>

Hockney favors skills while Hirst seems to favor freedom of production –which although inspired by contemporary models of mass production is a further extension of the freedom of creativity and leaves the artist free from the obligation of implementing the Kantian concept of rule bestowed onto the artist by nature.

This is the reason for my respect for the work of Jane Prophet which although innovative is strongly rooted in a classic tradition of references and contextualizations that do not deprive or suffocate the work but rather enrich it.

The references are not openly flaunted as if searching for a legitimacy –often seen in many derivative artworks that generate artistic phenomena of branding by association. Jane's work is an hard slog, a structured itinerary of explorations that present the viewer with an aesthetic object that is so surprisingly far away from its initial concept that it almost appears totally unrelated. The viewers' observation of the artwork is both an aesthetic enjoyment as well as an exploration of its history, inspiration, meaning and context. It is a journey back to retrace the itinerary of the artist who –through



*The reality is that E-scapes: Artistic Explorations of Nature and Science is an hymn to canons, observation (both scientific and aesthetic), explorations, structures and rules.*

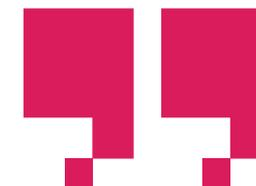

scientific and aesthetic observations, critical analysis, corrections and explorations– changes, adapts, molds and at times destroys old structures, canons and frameworks of perceptions, altering the 'traditional views' and suddenly making it so seemingly easy to look at and enjoy artworks that are innovative and simple but borne out of a long process of complex conceptual and historical entanglements.

If I don't argue that there is a part of the viewers' engagement with the artwork that is, and perhaps must be, attributed to taste, certainly there are also canons and traditions that forge the critical structures within which an artwork can be viewed and experienced.

The contemporary concept of artistic genius –with all of its undeniably positive influence– has also contributed to a culture of freedom that is not just a freedom from the hierarchal structures and the oppressive framework, as the futurists claimed at the beginning of

the 20<sup>th</sup> century, but has also become a freedom from knowledge itself. A ripping apart, destroying and ignorance of knowledge and skill that at best provide a playground for everything to be art and therefore for nothing to be art.

Both Jane Prophet and Paul Catanese, in their own artistic practices and with different methodologies –the reference to tradition and science in Prophet's case and the search for poetics from science in Catanese's work –structure their images as evocative in opposition to causality and rooting them in reverberation. "In this reverberation, the poetic image will have a sonority of being." The artist "speaks on the threshold of being." <sup>6</sup>

The *E-scapes* exhibition in its desire to follow the artists in their aesthetic itinerary envisaged the participation of the public –in one of its multiple possible itineraries– as a re-visitation of Henri-Louis

Bergson's concept of dynamic vital impulse. This is an aesthetic itinerary based not just on dynamic impulse but also on the wider contexts of participation and flowing as expressed by Eugene Minkowski's interpretation of Anna Teresa Tymieniecka's analysis of relationships in *Phenomenology and Science*.

After this description it may seem that I have declared my preference for structuralism versus idealism, modernism versus post-modernism, determinism versus indeterminism, textual monolithic interpretation versus multiple extratextual elements.

The reality is that if I were asked to take a stand my response would be that I would prefer to sit. This is because I am not interested in fitting neatly in this camp or that camp, along this ideology versus the other. And if my metaphor may be weak and perhaps a bit too witty, there is a passage by Umberto Eco that I believe conveys the complexity of the interaction of different approaches and methodologies in the creation of the artwork. "What I call open texts are, rather, reducing such as indeterminacy, whereas closed texts, even though aiming at eliciting a sort of 'obedient' cooperation, are in the last analysis randomly open to every pragmatic accident."<sup>7</sup> It is the equivalent of saying that not always labels and ideological constructs do encompass all explanations and do not always deliver what it is expected of them.

The artworks of Jane Prophet and Paul Catanese although constructed with rigorous and at times severe attention to the form, also embody the complexity of multiple interpretations and engagements and deliver more than expected. The artworks do not exhaust their fascination in a single journey of discovery, but exist simultaneously through multiple referential paths, despite or perhaps because of the punctilious and scientific structure of their aesthetic. The curatorial approach for the exhibition was structured to showcase the complexity of the artworks –by offering a a dissection of the multiplicity of implications and providing a glimpse into the journeys that these two artists have undertaken. ■

#### REFERENCES AND NOTES

1. Paul Guyer, *The Cambridge Companion to Kant* (Cambridge: Cambridge University Press, 1992): 390.
2. David Hockney has denied his critique to be directed at Damien Hirst –but instead to be addressed to contemporary artists who do not skillfully produce their work.
3. Gerald James Holton, *The Advancement of Science, and Its Burdens: With a New Introduction* (Cambridge, MA: Harvard University Press, 1998), 44.
4. Paul Guyer, *The Cambridge Companion to Kant* (Cambridge: Cambridge University Press, 1992): 390.
5. Andrew Marr, "David Hockney - An Artist for All Seasons: Britain's Greatest Living Artist Reveals How He Keeps His Mind Young," *RadioTimes*, January 8, 2012, <http://www.radiotimes.com/news/2012-01-08/david-hockney---an-artist-for-all-seasons> (accessed January 10, 2012).
6. Gaston Bachelard, *The Poetics of Space: The Classic Look at How We Experience Intimate Space*, trans. Maria Jolas (Boston, MA: Beacon Press, 1994), xvi.
7. Umberto Eco, *The Role of the Reader: Explorations in the Semiotics of Texts* (Bloomington: Indiana University Press, 1984), 7.

#### BIOGRAPHY

**Lanfranco Aceti** is the Director of Kasa Gallery in Istanbul, the Editor in Chief of the Leonardo Electronic Almanac and teaches Contemporary Art and Digital Culture at the Faculty of Arts and Social Sciences, Sabanci University, Istanbul.

# The World Needs Forms

Curator's Essay introducing LEA Digital Media Exhibition  
"E-escapes: Artistic Explorations of Nature and Science" featuring  
Paul Catanese & Jane Prophet.

Leonardo Electronic Almanac's digital media exhibition platform was inaugurated by a pair of projects developed by two established artists who throughout their respective careers have produced works that respond in highly personalised ways to the interdisciplinary potential afforded by creative technologies. In deciding to present Paul Catanese and Jane Prophet together during the autumn of 2010, LEA's curatoriate had hoped that some connections might be drawn from their respective artistic projects and that these resulting insights would be more than fortuitous. While the serendipitous relationships that did eventuate cannot be claimed fully by design on the curators' part, it is wholly welcomed nonetheless.

I find myself writing these initial observations from an exaggerated perspective... At this moment, the trajectory of a flight path is being traced over a small pixilated screen set into the chair-back facing me. This graphic representation is contrasted by the abstraction provided by my aerial vantage, looking out the window to my right, high above Western Australia. While jagged raster lines demarcate territories and trace trajectories, below, the terrain is scored by scales and fine tracks that mark currents (of wind and possibly water, long evaporated) that have coursed across the surface of the land and define the contours and shifting materialities of surface (sand, scrub, bush and brush). Fine grained, dusty and vaguely defined expanses form into colour fields of puce and orange. Green tinged shadows are unexpectedly interrupted by the localized shimmer of light bouncing off a small cluster of built structures; presumably steel or aluminium clad.

Viewed in juxtaposition, Paul Catanese's "Visible from Space" and Jane Prophet's "Explorations of Structure" are related by an apparent contradiction: different but same, same but different. Their distinctively different artistic and aesthetic motivations are exercised by a common sense of curiosity. Catanese's vision is magnetically attracted to the desert; first down to its dry, scratched earthiness, then up to its cold, clear light. While Prophet is drawn to the pastoral, green and rich with the promise of moisture. Both artists, similarly, apply imaginative projection to propose future scenarios, while communicating different expressive qualities. Each fuels their individual artistic program from the layering and comingling of different systems, whether natural or human. In searching for orders that may extend beyond the natural sciences, might their projects even be deemed *psycho-climactic*? Both are intrigued by the widest range of human, cultural, scientific and technological interventions of the land and how these propagate different ecologies, landscape traditions, belief systems and boundaries. In order to communicate something about this, their art draws upon a variety of cultures of visual language (diagrammatic, graphic, perspectival and photographic). Designed initially in direct response to the particular opportunity presented by the online exhibition structure of LEA's social media platforms, Catanese and Prophet made use of the building blocks of word and picture to compose meaning and explication, using this amalgamated format as tool to systematically interrogate as well as weave a form of allusive poetry.

The relation between their individual projects might be figured paradoxically as parallel lines of enquiry that converge and intersect before continuing along their distinct courses. Over the month of September 2010, Paul Catanese presented a formative project developed during a residency in Death Valley. The resulting portfolio of images is a portent to further potentialities by acting literally (and figuratively) as groundwork. Proceeding from a different direction, Prophet's exhibition the following month took the opportunity to undertake a process of reflective analysis. As the images selected unfolded sequentially throughout October, the rich seams and resilient threads that connect an artist's creative production over a number of years are retrospectively unearthed.

A quality that is shared by both artists and sustains their different creative practices is their sense of astonishment. In analyzing art as a social and perceptual system, Niklas Luhmann (2000) writes how astonishment:

*affects not only the observer of art but also the artist. The observer may be struck by the work's success and then embark on a step-by-step reconstruction of how it came about. But the artist is equally struck by the order that emerges from his own hands in the course of a rapidly changing relationship between provocation and possible response, problem and solution, irritation and escape. This is how order emerges from self-irritation, which, however, requires the prior differentiation of a medium of art to decide that this order differs in its stakes from what occurs elsewhere in reality. (p.146-7)*

Two dusty tracks run off side by side towards the horizon. No water, nor even the promise of any down there... While up here, viewed at eye level through my window there spans a layer of stratospheric

haze that in its own formless way demarcates the terrestrial from ultramarine blue sky. When I shift my focus to the surface plane of the airplane's window, I notice that it is marked by finely etched filaments of condensing ice.

The otherness of the desert below presents itself to me as strangely familiar, reminding me of the ridges than run across the pads of my fingertips. As I tap out these words at the speed of 500mph from the abstracted altitude of 36,000ft, my recollection of the works produced by Paul Catanese and Jane Prophet make me think about humanness –theirs as much as mine, and any other viewer of their work –and how the structure of exploration underlies our very being.

## Vince Dziekan

### NOTE

The title of this essay and quoted reference are drawn from Niklas Luhmann's *Art as a social system*. See Luhmann, N. 2000. *Art as a social system*. Transl. E.M. Knodt. Stanford, CA: Stanford University Press.

### LEA International Curatoriate:

Curator: Vince Dziekan, (Monash University and FACT Associate).  
Senior Curators: Lanfranco Aceti (Goldsmiths College and Sabanci University) and Christiane Paul (The New School and Whitney Museum of American Art).

## Vince Dziekan

Vince Dziekan is Associate Dean Research in the Faculty of Art & Design at Monash University in Melbourne, Australia. In addition, he is affiliated with the Foundation for Art & Creative Technology (FACT) in Liverpool, UK as a FACT Associate and is Digital Media Curator of The Leonardo Electronic Almanac (LEA).

# Jane Prophet

## *Explorations of Structure*

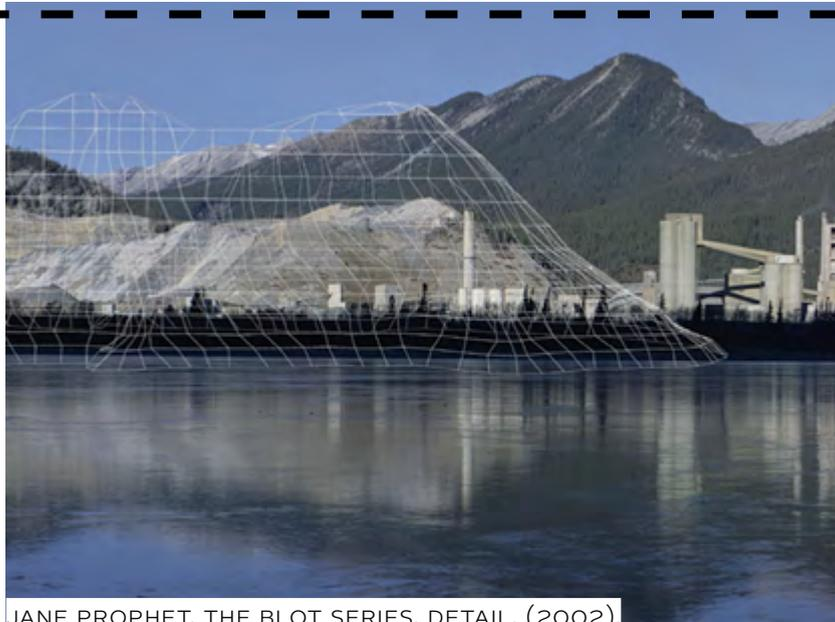

JANE PROPHET, THE BLOT SERIES, DETAIL, (2002).  
STRUCTURE OF LANDSCAPE: WHAT IS NATURAL?

Dawn at The Lafarge Exshaw plant, Lac des Arcs, Alberta, Canada.  
These photographs were taken in November 2002 during a visit to  
Banff Centre for the Arts, using a 6:17 Fuji panoramic camera.



Elements of these art pieces are derived from fractal mathematics. The 'blot' series takes its name from the process of using a 'blot' or random instant mark as the source of inspiration. Gordon Selley's mathematical code makes the trees in these images and generates different 3D forms each time it runs. Prophet responds to the images and the code is altered accordingly to produce different outputs. Small changes to random numbers in mathematical equations result in huge shifts in the final form of the works.

The composition of the final images is a response to the V&A's British Watercolour Collection. The landscape scenes are of The Lafarge Exshaw plant, Lac des Arcs, Alberta, Canada. These are the first in a series of new works by Prophet exploring locations that combine reflecting pools and natural 'sublime' landscapes with icons of the industrial or technological sublime (aggregate works, power stations and other 'cathedrals' of industry).

JANE PROPHET, THE BLOT SERIES, LAC DES ARCS,  
CANADA AT DAWN, (2002).  
STRUCTURE OF PARKLANDS AND WILDERNESS.



JANE PROPHET, THE BLOT SERIES:  
DETAIL, LAC DES ARCS, NIGHT, (2002).  
**STRUCTURE OF BEAUTY.**

The works were a response to the Victoria & Albert Museum's British Watercolour Collection. Exhibited at the Victoria and Albert Museum, London as part of the 'Digital Responses' series curated by Paul Coldwell.



JANE PROPHET, THE BLOT SERIES, LAC DES ARCS,  
NIGHT, (2002).  
**STRUCTURE OF BEAUTY.**

The landscape scenes are of The Lafarge Exshaw plant, Lac des Arcs, Alberta, Canada. Each image is a Lightjet print, 80" x 26.5", backed with aluminium and front mounted with acrylic. An Edition of 10.

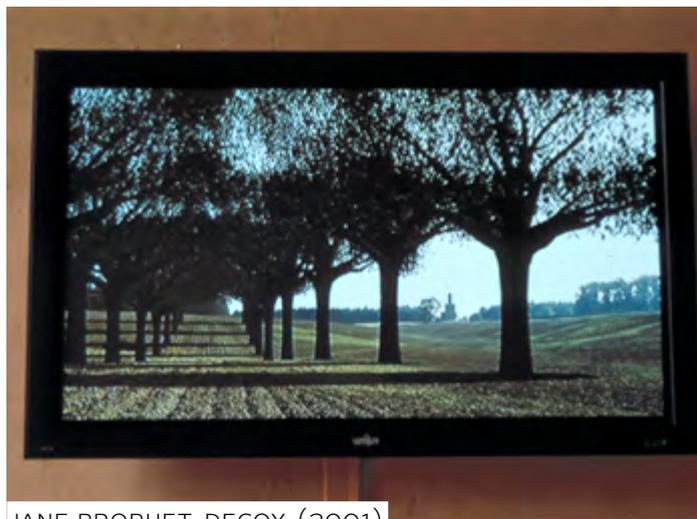

JANE PROPHET, DECOY, (2001).

STRUCTURE OF OAK TREES AND ENGLISHNESS.

A screen based digital work reflecting on the politics of landscape, construction and ownership. Drawing on works by painters such as Gainsborough and Poussin as well as the creations of landscape designers Humphry Repton and "Capability" Brown, Decoy consists of a series of animated digital "paintings", displayed on plasma-screens, in which subtly evolving fractal landscapes are combined with photographic images of the views of the grounds of various country houses.

English oaks once formed an avenue in the parkland at Blickling Hall. Most were removed to form the characteristic clumps of trees favoured by Capability Brown and Humphry Repton. Using the existing trees as a guide, the avenue is reinstated.

This quintessentially English, Arcadian vista has entered the popular imagination as an embodiment of Nature and the Natural, yet it is almost entirely artificial in its construction. By combining these vistas with evolving simulated landscapes, Prophet unearths the artificiality of each landscape's past, either by returning the setting to a closer approximation of "wild" nature, or by allowing the viewer to project ahead into the future, according to different growth and planting patterns.



JANE PROPHET, DECOY, INSTALLED IN THE ORANGERY AT BLICKLING HALL, ENGLAND, (2001).

STRUCTURE OF PARKLANDS AND WILDERNESS.



JANE PROPHET, DECOY, (2001).

STRUCTURE OF COLLECTING PAINTINGS AND COLONIALISM.

As part of 'Life is Beautiful', 'Decoy' was double hung with 18<sup>th</sup> & 19<sup>th</sup> century watercolours from The Laing Gallery's permanent collection. In this showing the work drew attention to its relationship to painting.



JANE PROPHET, DECOY, (2001).

STRUCTURE OF TREE BRANCHING PATTERNS.

Test computer rendering of tree form for 'Decoy'. Based on algorithms by Gordon Selley, this tree was used as the basis for developing data sets that could be used to make Rapid Prototyped trees.

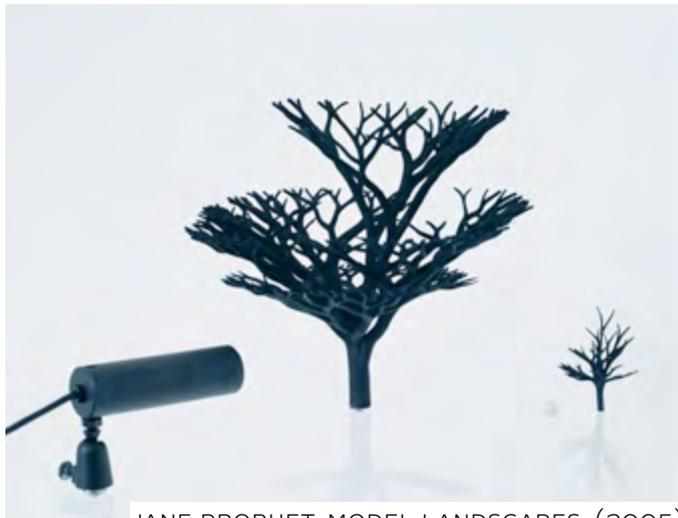

JANE PROPHET, MODEL LANDSCAPES, (2005).  
STRUCTURE OF IDEALS.

Shelf work component of Rapid Prototyped tree piece. 'Model Landscapes' engages with our desire for the perfect landscape and our willingness to mold or model these via large and small scale interventions. Prophet created a series of 'Model Landscapes' of fictional states which co-exist alongside recognisable landscapes.

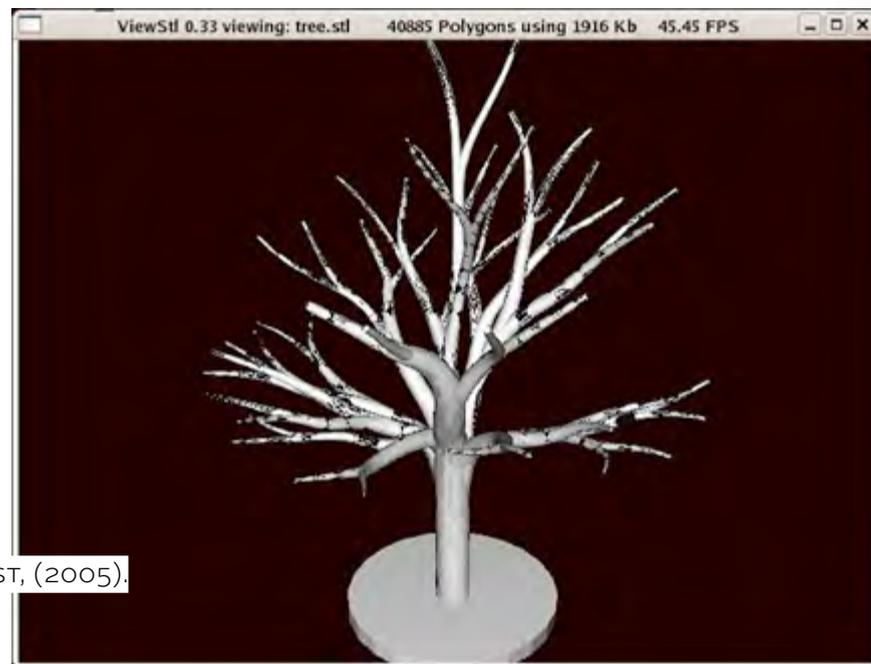

JANE PROPHET, TEST, (2005).

Early test showing an algorithmic tree structure in a form that (finally) the Rapid Prototyping machine could use.



JANE PROPHET, MODEL LANDSCAPES, (2005).  
STRUCTURE OF MEDIATION.

Screen component Rapid Prototyped tree piece. Each of these works addressed ideas of model or 'ideal' landscapes. In contrast to her large installations, Prophet has created new miniature landscapes viewed on small monitors, drawing the viewer in and demanding close inspection. These small object based vignettes are subject to surveillance by cameras.



JANE PROPHET, SOUVENIR OF ENGLAND, (2007).  
STRUCTURE OF ORCHARDS AND HERITAGE SPECIES.

Since they were first made in 1898 to commemorate the building of the Eiffel Tower, Snow Globes have been used as mementos to encapsulate key landmarks. They have become the quintessential souvenir object, now slightly outdated and nostalgic themselves. Shaking them brings the scene to life for a brief and artificial moment of suspended disbelief.

This dome is a memento to the English orchard which is fast becoming an endangered species. The apple tree inside died in a commercial orchard, its contorted shape a result of pruning.



JANE PROPHET, SOUVENIR OF ENGLAND, (2007).  
STRUCTURE OF GARDEN DESIGN.

The 28 ft snow dome with tree inside is installed in the orchard at Hanbury Hall. Curated by Anne de Charmant.

Note the cow parsley in the foreground.



JANE PROPHET, (TRANS)PLANT: COW PARSLEY, (2008).  
STRUCTURE OF WEEDS.

Cow parsley (*Anthriscus sylvestris*). This native British plant is familiar to people living in both rural and urban areas where it can be found on railway banks, in ditches, at woodland edges and on waste ground. In the past children used the hollow, furrowed stems of this plant as pea-shooters.

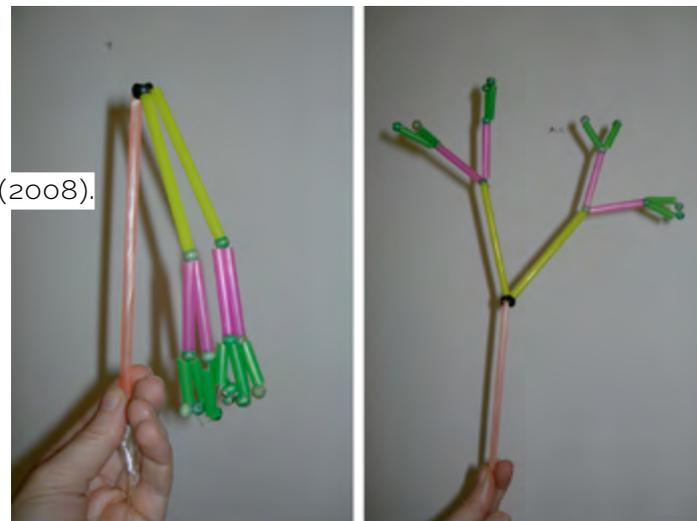

JANE PROPHET, (TRANS)PLANT: DRINKING STRAW MODEL, (2008).  
STRUCTURE OF PLAYFULNESS.

In combination with the cow parsley structure, Jane wanted a playful movement for the kinetic sculpture. She wanted it to seem to collapse and reform, inspired by the classic toy Sampo (first made in 1945) by the Swedish brand Brio.

A simple drinking straw model tested this out with a branching plant form.

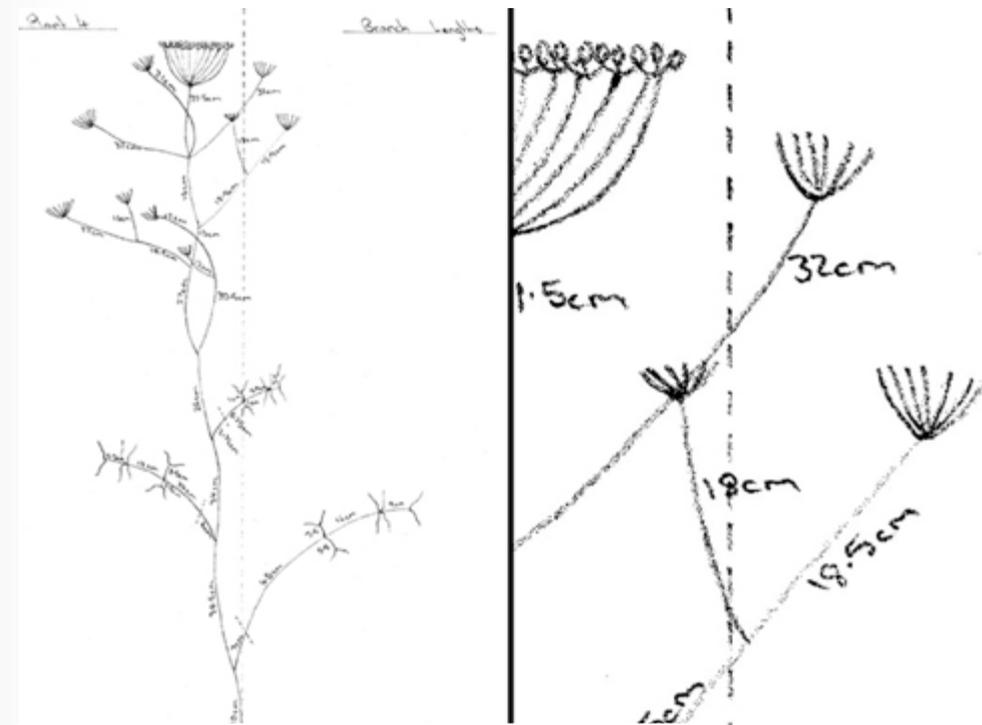

JANE PROPHET, (TRANS)PLANT: JULIAN VINCENT SKETCH, (2008).

STRUCTURE OF NATURE AND GEOMETRY.

Cow parsley is of interest to mathematicians and engineers because it (and other members of its family such as Giant Hog Weed) show geometric consistency over a very wide size range in an order of magnitude ranging from less than 1m high to 7m.

This suggests that, within limits, whatever the size of the structure of '(Trans)Plant' one can predict the sizes, lengths and angles needed to produce a structure of any given size. This geometric consistency also means that the resulting sculpture will look both biological and familiar.

Using the measurements of cow parsley that Professor Vincent has in his extensive database of natural structures, we can predict the design of a structure up to twice the height of the biggest known similar plant (7m).

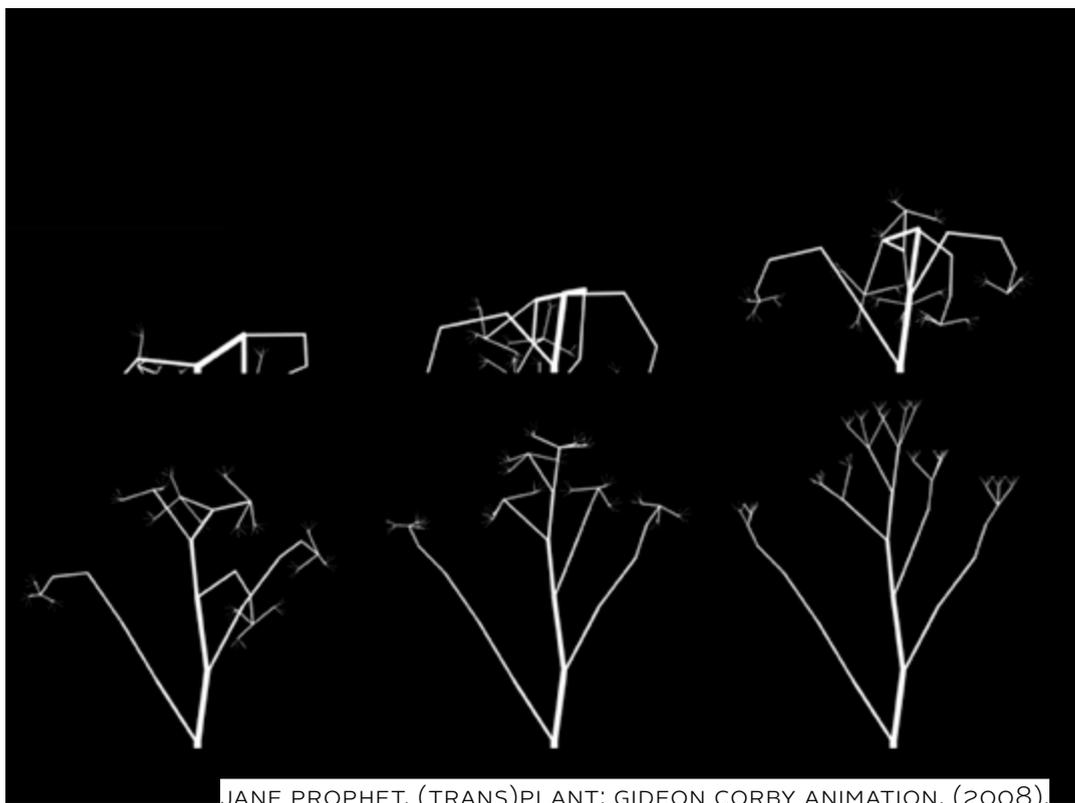

JANE PROPHET, (TRANS)PLANT: GIDEON CORBY ANIMATION, (2008).  
**STRUCTURE OF MOVEMENT.**

Jane Prophet was born in Birmingham. Her father, David, began his career as an apprentice at Birmingham's Austin Motor works. He was fired for spending too much time working on his racing cars (while someone else clocked on for him) and for insubordination, evidenced by late night welding sessions in the factory workshop that resulted in giant amalgamations of metal work.

The design process and materials of Prophet's piece '(Trans)Plant' which was made specifically for Birmingham reflect her father's love of mechanics and his respect for innovative manufacturing.

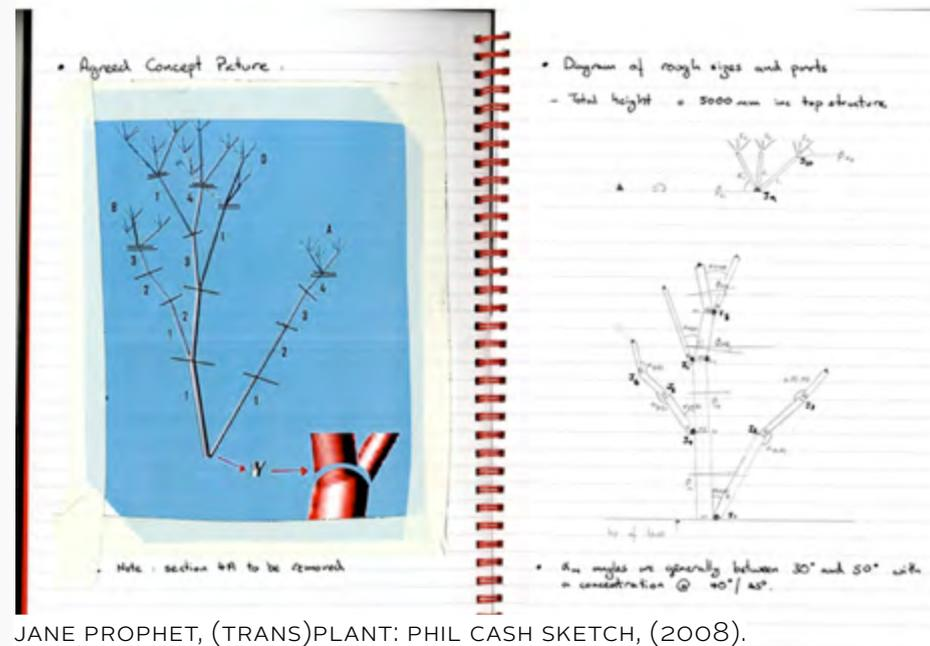

JANE PROPHET, (TRANS)PLANT: PHIL CASH SKETCH, (2008).  
**STRUCTURE OF BIRMINGHAM.**

JANE PROPHET, (TRANS)PLANT: ENGINEERING DRAWING, (2008).

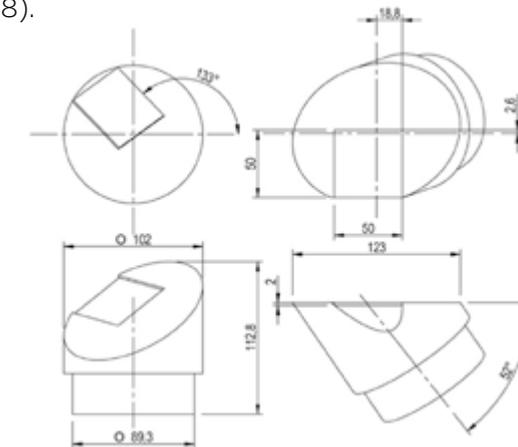



JANE PROPHET, (TRANS)PLANT: IN PROGRESS, (2008).  
**STRUCTURE OF TRANSPLANTATION.**

(Trans)Plant:

1: a type of experiment where an organism is moved from one location to another

2: Different species and varieties react differently to transplanting; for some, it is not recommended.

Avoiding transplant shock –the stress or damage received in the process –is the principal concern.



JANE PROPHET, (TRANS)PLANT: INSTALLED, (2008).  
**STRUCTURE IN THE CITY.**

The kinetic mechanical art work installed for 2 weeks in Birmingham.  
 Shown collapsed and beginning to open.



JANE PROPHET, (TRANS)PLANT: INSTALLED, (2008).  
STRUCTURE OF METALS.

'(Trans)Plant' is equally influenced by her close relationship with Arthur Watkins, her maternal grandfather, from Sparkhill, a metallurgist who entertained her by making objects out of wire and showing her how mercury behaved. Her fascination with plants and their shapes started during her childhood and came from his discussion of plant chemistry and her mother's life-long passion for horticulture and garden design.



JANE PROPHET, (TRANS)PLANT: INSTALLED (DETAIL), (2008).

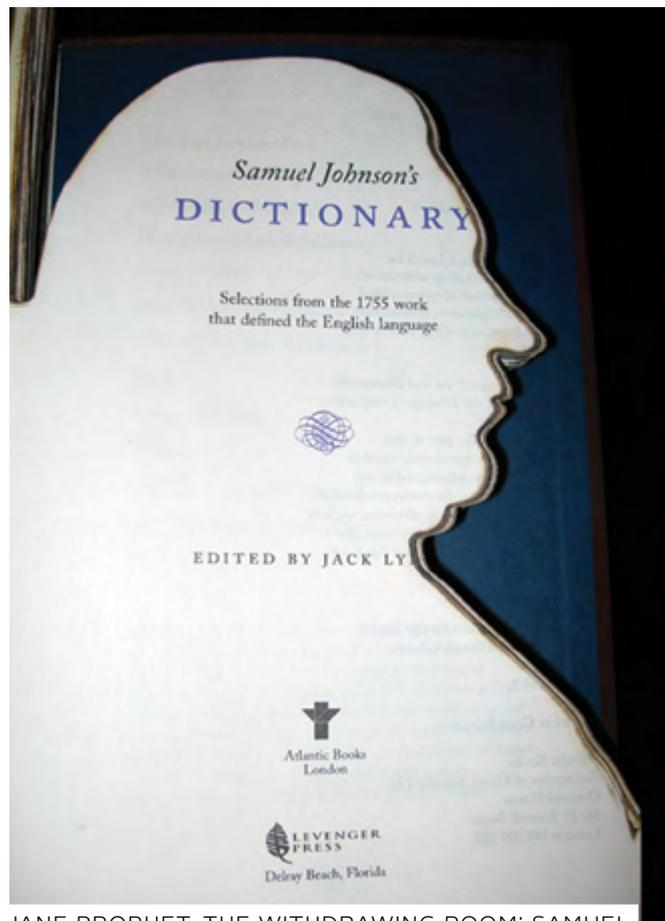

JANE PROPHET, THE WITHDRAWING ROOM: SAMUEL JOHNSON (DETAIL), (2009).  
STRUCTURE OF LANGUAGE.

To mark the Tercentenary of the birth of Samuel Johnson there was an exhibition of works by a group of artists from June-September 2009, set within, and in response to, the house where Samuel Johnson compiled one of the first English Dictionaries.

Samuel Johnson, 1709-1784, was widely regarded as the leading literary figure of his time, so much so that it is often referred to as the "Age of Johnson". He was (amongst other things) a poet, biographer, lexicographer, essayist, editor and reviewer of the English Dictionary. Prophet's works comprised of a series of laser-cut books, the first of which is shown here, cut through with Samuel Johnson's profile.

A commemorative Jasperware medallion of Johnson was issued by Wedgwood in 1784. Jane Prophet's Portrait of Samuel Johnson, a dictionary in which a profile of Samuel Johnson is cut through the pages (produced in an edition of 10) offers a comparable memento.



JANE PROPHET, THE WITHDRAWING ROOM: SAMUEL JOHNSON INSTALLED, (2009).  
STRUCTURE OF DICTIONARIES.

The works were all produced to be installed at Samuel Johnson's House. Johnson gradually acquired a reputation in the literary world, and in 1746 he was commissioned by a consortium of printers to write a dictionary of the English language. At this time he rented 17, Gough Square, London, which served as both home and workshop for the Dictionary. While working on the Dictionary, he also published a series of essays under the name "The Rambler", and contributed to "The Adventurer" essays. (He was later to write another series as "The Idler".)

The Dictionary of the English Language was eventually published in 1755. It was not (as is often claimed) the first English dictionary, but it was certainly the most important one published up to that date. It went through numerous editions, and was not superseded until the publication in 1928 of the Oxford English Dictionary.



JANE PROPHET, THE WITHDRAWING ROOM:  
LEAF, (2009).

**STRUCTURE AND DEFINITION.**

Johnson's definition of LEAF: The green deciduous parts of plants and flowers. A Part of a book containing two pages.

It is well-documented that Samuel Johnson was hard on books, capable of 'tearing the heart' out of them and leaving them –as if discarded– on table or floor as soon as they had served his immediate purpose. But these specimens, with their pages so precisely and impressively laser-cut, are clearly not the result of careless treatment.

Prophet is interested in the way familiar objects can be adopted as symbols, for example, the use of the oak tree as shorthand for 'Englishness'. In this installation she has transformed standard dictionaries by designing computer fonts to facilitate the laser-cutting of shapes of words and objects that evoke ideas of Johnson's life and work.

Collectively the books symbolize his achievements as the leading literary figure of his time.



JANE PROPHET, THE WITHDRAWING ROOM: WEDGE, (2009)  
**STRUCTURE OF BOOKS AS OBJECTS.**

The old floors of Samuel Johnson's House slope dramatically at times. The dictionary, open at the page for "wedge" props up the antique display case and keeps it level.



JANE PROPHET, THE WITHDRAWING ROOM: OATS, (2009).  
**STRUCTURE OF RUDENESS AND HUMOUR.**

Johnson's definition for OATS: A grain, which in England is generally given to horses, but in Scotland appears to support the people.

In the background: DENDROLOGY: The natural history of trees.



JANE PROPHET, THE WITHDRAWING ROOM: LACE, (2009).  
**STRUCTURE OF LACE.**

COLBERTINE: A kind of lace worn by women.

Displayed amongst objects in the permanent collection.



JANE PROPHET, MY SILVER STALKING JUBILEE: WORK IN PROGRESS, (2011).  
STRUCTURE OF PSYCHOSIS.

I have been stalked for 25 years. It's the kind of thing one commemorates privately. Or not. I have received hundreds of letters. For a month in 2000 I kept the letters. They form the starting point of this photographic series.

I selected sentences from them and keywords from these sentences. I typed the words, one at a time, into Google image search.

I then set up an A3 document and wrote the whole sentence from the letters, containing the word, in to the document. Next I placed images from the search into the document and worked intuitively, removing images until I had a combination of one image and a line of text from the original letters.

I went back to Google and searched for the exact object that I had an image of, but that was for sale. I bought all the objects and had them shipped to my studio in London. I arranged to do a professional high resolution studio shoot with my friend, the artist, Bill Jackson.  
Image: No. 1 Catwoman

0000 The letter 'o' in your font is too big. You don't write your letter O with generous abandon, you might want to enclose my world but your letter O is small. So now I'll go and look again at your letters to me, look closely at the way you form your letters.

I don't want to.

It's like looking at the surface of your skin, breathing your sweat, which I remember from when you tried to abduct me, when you kept out as I walked along a street in London, when you closed your hand over my mouth, when you dragged me backwards and lifted my feet off the ground so I struggled and walked like your puppet. I remember that your sweat smelled of medicine, that somehow you smelled all wrong and the fear I felt and my desperate struggle to get away from you intensified and was a huge thing, driven by that smell that with my mouth sealed by your hand shockingly warm on that smell of you became my whole world for a few seconds. I was encircled by it I drowned in it and I thought drowning and death might be nice and I relaxed and then I wanted to live and I had the strength of a thousand men as I struck out struck you kicking for the surface I was an animal and I wanted to live and you were only my enemy the only thing between me and life between me and air.

Oh Oh The breath my breath, writing my breath in your hand, holding my breath behind your hand let writing but being.

Two men fought you off I ran you closed me I felt over a tear. You followed. Passengers stood between us. The bus driver came out of his seat, he left the acrylic barrier behind, he helped to bring you off the bus.

I sat on the upper deck and with I look I look I look I noticed that I breathed and there was no wrong smell. I think the smell of me, the all encompassing smell of my fear.

0000 The letter 'o' in your font is too big? With generous abandon, you might want to letter O is small. So now I'll go and look again closely at the way you form your letters.

I don't want to.

It's like looking at the surface of your skin which I remember from when you tried to abduct me out as I walked along a street in London your hand over my mouth, when you dragged my feet off the ground so I struggled and puppet, I remember that your sweat smelled of medication, that somehow you smelled all wrong and my desperate struggle to get away intensified and was a huge thing, driven mouth sealed by your hand shockingly warm on that smell of you became my whole world for a few seconds. I was encircled by it I drowned in it and I thought drowning and death might be nice and I had the strength of a thousand men.

JANE PROPHET, MY SILVER STALKING JUBILEE: WORK IN PROGRESS, (2011).

STRUCTURE OF HANDWRITING.

While 'My Silver Stalking Jubilee' may seem like a departure from the previous works, it is really similar. Not so easy to make, but nevertheless an exploration of structure. The structure of the stalker's letters, the structure of his mind, the structure of his handwriting.

I have made a font by tracing his hand writing and then written a series of texts with the font.

I wrote a piece at each stage of designing and testing the font.

My rule was to only write about the experience of using the font.

This is Letter No.6 and a close up of one section of it.

# Interview with Jane Prophet, “Explorations of Structure” by Lanfranco Aceti and Vince Dziekan

Interview with artist Jane Prophet initially conducted via Facebook during her online exhibition “Explorations of Structure” with Leonardo Electronic Almanac in October 2010.



**Vince Dziekan (LEA Digital Media Curator)**

Firstly, welcome Jane!

Over the past few weeks we’ve enjoyed the progressive unfolding of the project you’ve put together in response to LEA’s new digital media exhibition platform. You’ve titled the project “Explorations of Structure”. Having just passed the midway point of the exhibition, it has become quite apparent how your practice is driven by an incredible curiosity. You’ve successfully shown how your work over a number of years has been underpinned by a wide range of interconnected interests, spanning themes such as the sublime and beauty, natural order and human mediation of the landscape.

To me, your work is constructed as a type of utopian project; and as such, its imaginative excitement can be described as coming from “the recognition that everything inside our heads, and much outside, are human constructs and can be changed” (I’m drawing here from the introduction to ‘The Faber Book of Utopias’). I’m wondering if this resonates with how you see your work?



**Jane Prophet**

My gut reaction was to resist the idea that I am engaged in a utopian project. But then I paused to consider that the notion of utopia is equally a ‘construct that can be changed’ and so I reluctantly agree.

The landscape theme in my work is very much about exposing how ‘constructed’ so-called utopian or sublime experiences of nature are. I haven’t been able to access the Faber introduction that you refer to but take the position that utopian thinking, while problematic, can be used to imagine alternative visions of the future, which is how I would fit works like ‘Decoy’ into thinking about utopia.

Writing about social change and its relationship to utopia, Tony Stevenson comments on John Carey’s Faber and Faber introduction and says, “it is where we store our hopes of happiness. But this commonly held notion of utopia as a good place is probably not what Thomas More had in mind when he coined the word. It simply means nowhere or no-place, devoid of either optimism or pessimism. Whether conveying either desires or fears, Carey sees a dilemma. In seeking to create a new world, utopian projects must destroy the old.”

This interests me for a number of reasons: Thomas More’s notion of utopia as a non-place resonates with thoughts of landscape and utopia. What is a non-place? An impossible goal? Something that exists only in the imagination? A place forever lost? I am also struck by the concept that utopian projects must destroy the old, which smacks of the tired debate about digital media and how they ‘must’ destroy books, face-to-face communication etc and reminds me of the post-human cryogenic fantasy of a disembodied future (the ultimate de-manifestation of the Cartesian project). The very idea that utopian projects must destroy the old seems utopian indeed.

Stevenson goes on to suggest that there is, “a role for visions, or eutopias, as sets of ideas, in creating social change. And if a preferred vision seeks a future unfettered from the limitations of the status quo, critical thinking is necessary in formulating that vision...” This is the kind of role I hope my visions have, what I aspire to. That on a very small scale the works question and erode the status quo and prompt critical thinking at some level.

Reference: <http://www.tonystevenson.org>



**Vince Dziekan**

At this point in the unfolding presentation of your project, the most recently posted image is of an engineering drawing related to your ‘(Trans)Plant’ project. My curiosity was piqued when I recognized that this is the first time in the series that an image of yours has not been accompanied by a descriptive entry. I’m intrigued by what possible significance this blank, pause or breathing space might play in the overall exposition of your work. So, I’m wondering if you might like to bridge that gap by commenting on how your work connects ideas relating to the organic with the mechanical?



#### Jane Prophet

Good point. This is a page from engineer, Phil Cash's sketchbook. The image on the left is a still (thanks to Gideon Corby) from an animation that was made to give the engineer a sense of the movement I was hoping to emulate.

Why the 'blank'? Maybe because it is not 'my' image. But also, on reflection, it was an important break-point in the development of the piece. This drawing marks the moment when the graceful and elegant movement in my mind's eye collided with the stark engineering truth of aluminium/aluminum and motors!

We got movement which was less smooth than I'd hoped (yet actually closer to how those jointed wooden toys work). The whole sculpture became literally heavier and visually heavier.

During the process of developing and making the work this image does coincide with me taking a breathing space and taking stock.

We all moved forward and the piece looked much like this when complete.



#### Philip Cash

Interesting that you highlight grace and elegance here, where as my perspective at the time was much more heavily influenced by the mechanisms of the toy and the idea of the plant structure playing against that toy like theme.

In terms of the sketching and development of the final configuration, this was very heavily influenced by pragmatic considerations such as available materials and complexity. Also the idea of the toy weighted heavily on some of my decisions leaning me towards a more chunky design.

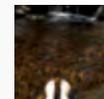

#### Jane Prophet

Yes, Phil, you are correct. The movement of the toy was MORE essential. There was always a tension in this idea between the way those toys move and the elegance of the plant. It was more important to get that movement closer to the toy (which you did, wonderfully).

A number of the works shown as part of this online posting embody similar tensions, as I explore different levels or types of structure in one piece. In most cases choices are made such that one theme dominates in the end, and it's always sad, but essential, to let go of some interests to hone down and declutter the final work.

When the piece was installed I loved the way it looked so broken, then 're-formed' then broke down.



#### Lanfranco Aceti (LEA Editor in Chief and Senior Curator)

Jane, I'm interested in your response to Philip's comments about the animate qualities of your work. Particularly, your observation about the tension that inevitably exists between ideation and its activation through your work. You've been able to give us a real insight into the ideas and inspirations that have lead towards the realization of certain pieces. Given that, I'm wondering how you see your work as initiating processes of perception, cognition and audience interaction and how this sets in motion ideas and interpretations in turn for viewers?

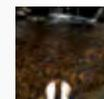

#### Jane Prophet

Some of the tensions between an idea and how it is finally manifest/embodied in a piece of work are never resolved in "that" particular piece. This results in the 'unfinished' idea often being re-addressed in a later piece of work.

For example, 'The Blot Series' and 'Decoy' started an exploration of landscape design and its relationship to what we 'believe' is 'the natural'. I became more and more interested in the object and physical presence but could not explore that fully within the confines of those work, so went on to make 'Model Landscapes'.

Of equal significance to how subsequent works develop is the impact of audience interaction and response.

For example, if the ideas that I had intended to set in motion get reflected back to me by people engaging with the work as they talk about it, I feel the work is more complete. But often the audience raises important questions or has a radically different interpretation which may prompt me to go in another direction.

So, with a piece 'Souvenir of England' a number of people interpreted it as a comment on global warming (which was not my intention) and that response has lead me to reconsider my approach to landscape and to start to develop ideas that address contemporary concerns about ecological issues. I now believe that such issues are intrinsic to our contemporary 'reading' or understanding of nature.

# Paul Catanese

## *Visible from Space*

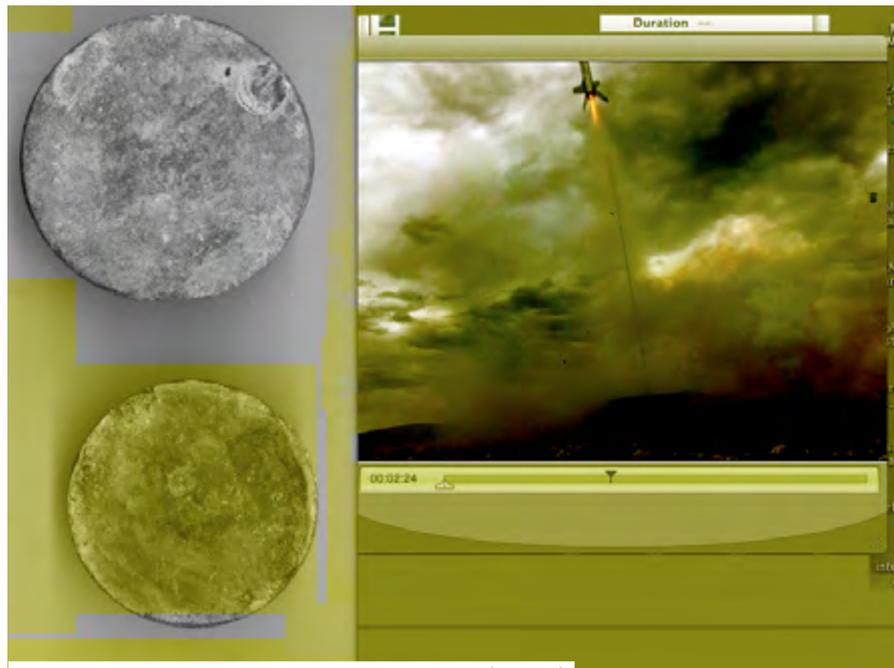

PAUL CATANESE, VISIBLE FROM SPACE, (2010).

"Visible from Space" by Paul Catanese. Research and development for "Visible from Space" was supported by a month-long residency in June 2010 at the Goldwell Open Air Museum, just outside of Death Valley.

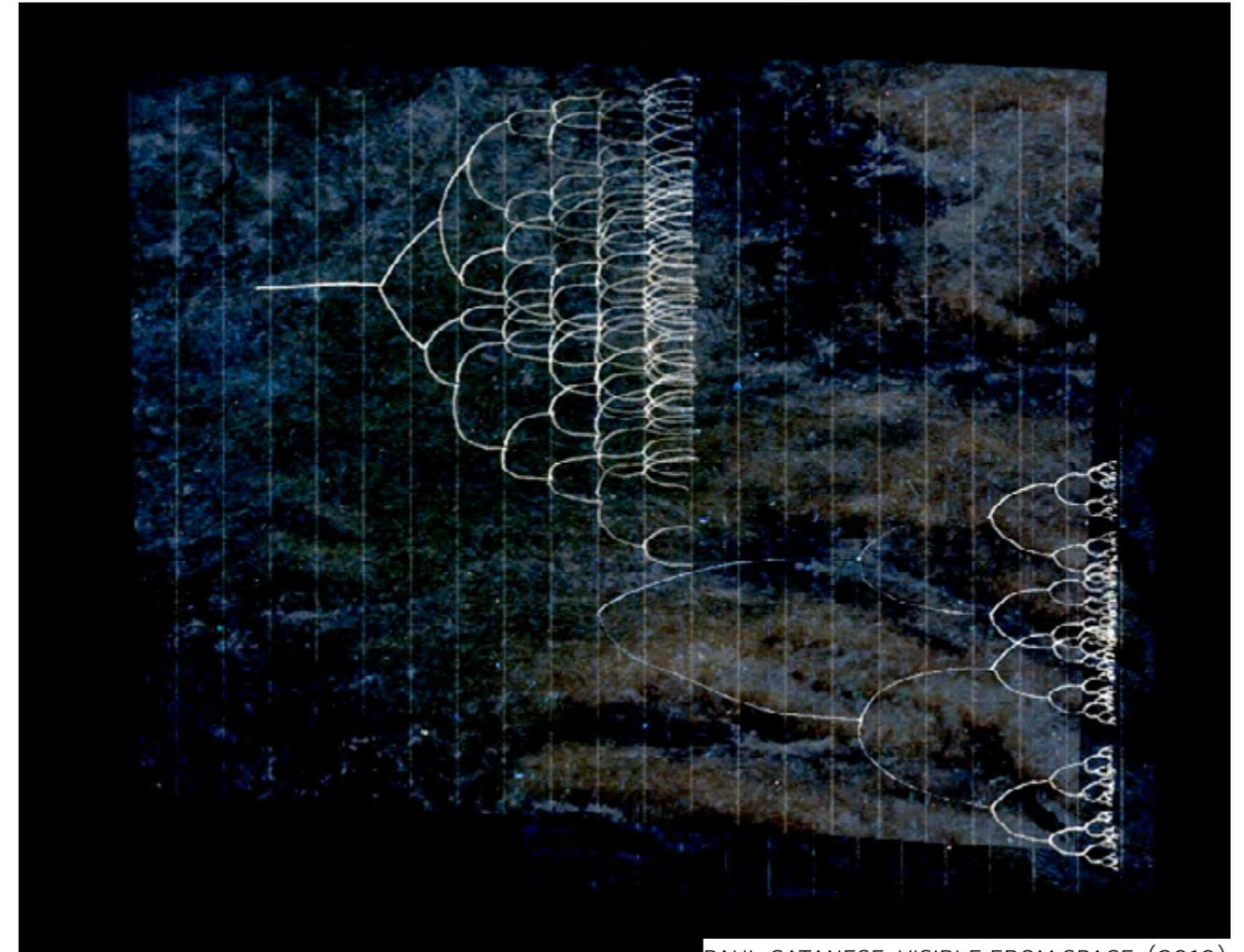

PAUL CATANESE, VISIBLE FROM SPACE, (2010).



PAUL CATANESE, VISIBLE FROM SPACE, (2010).

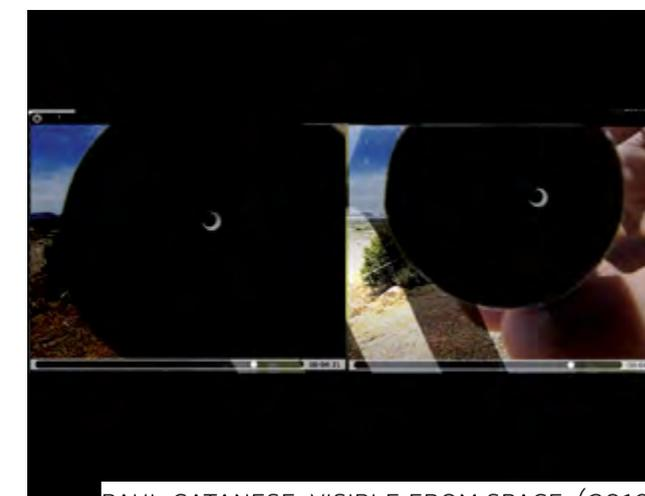
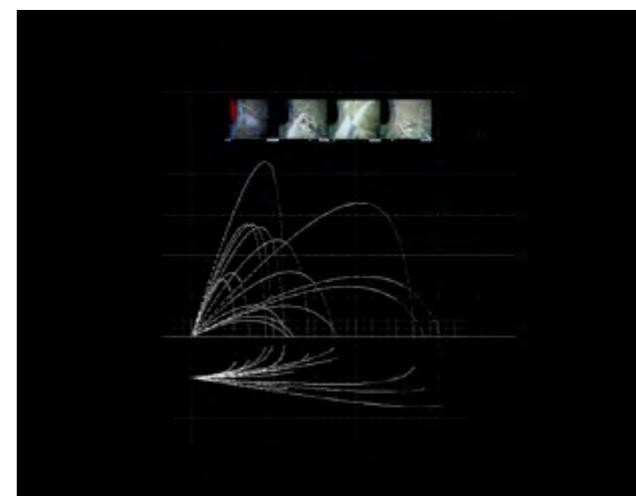
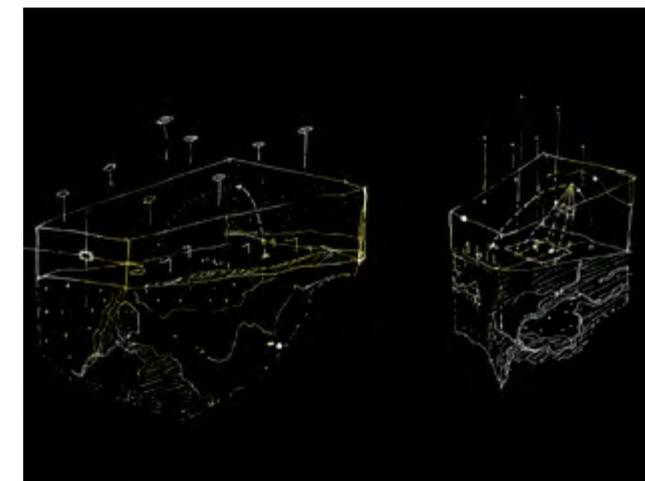

PAUL CATANESE, VISIBLE FROM SPACE, (2010).



PAUL CATANESE, VISIBLE FROM SPACE, (2010).

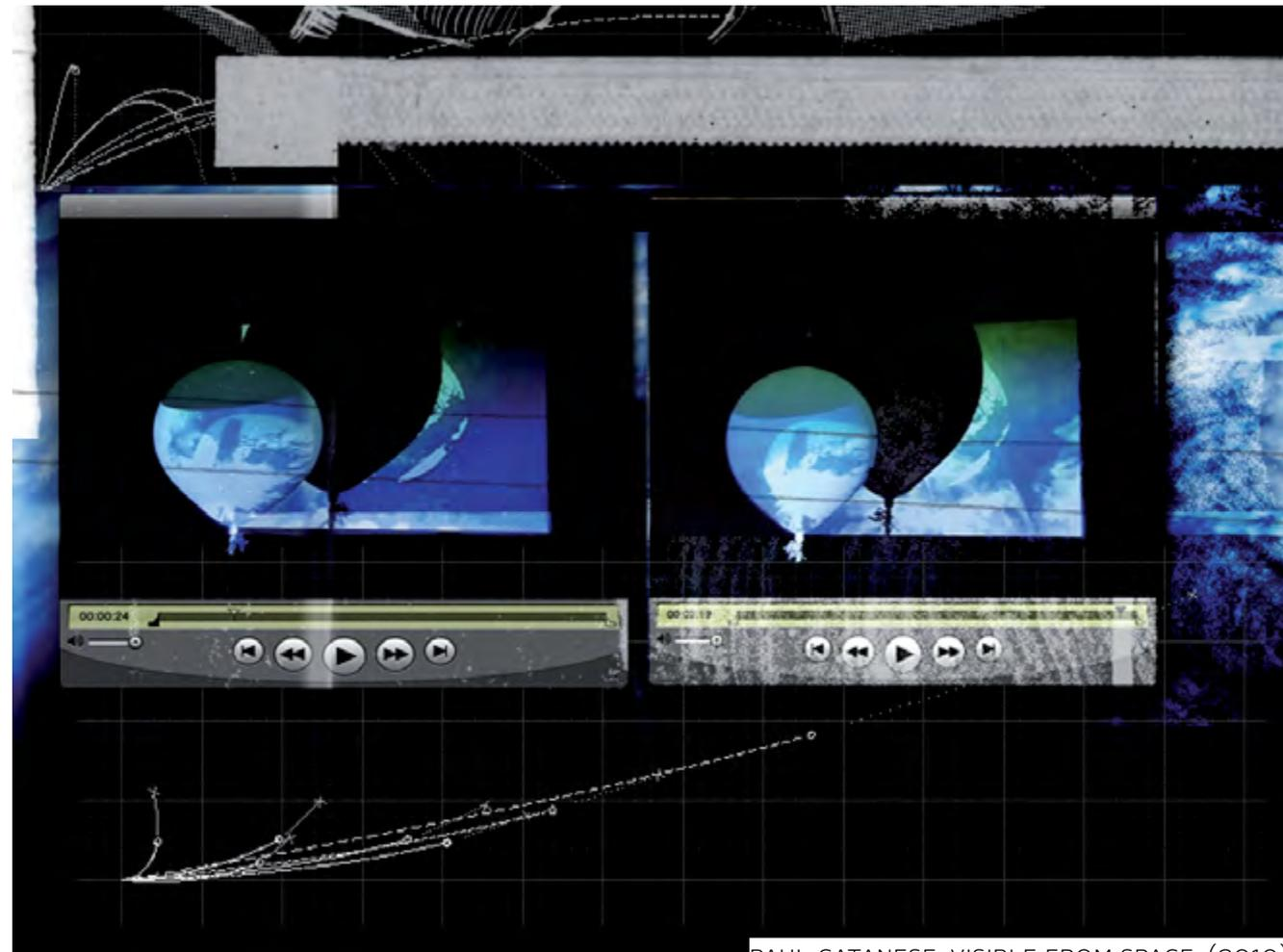

PAUL CATANESE, VISIBLE FROM SPACE, (2010).



PAUL CATANESE, VISIBLE FROM SPACE, (2010).



PAUL CATANESE, VISIBLE FROM SPACE, (2010).

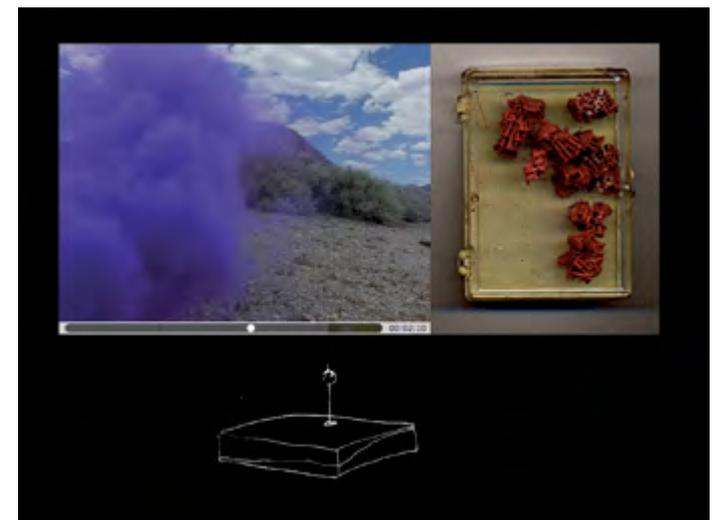

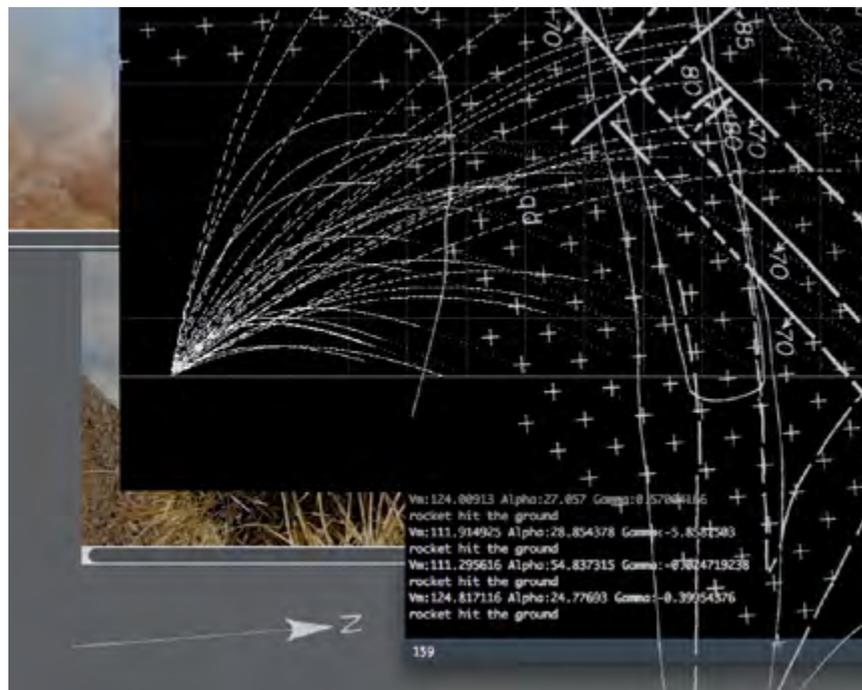

PAUL CATANESE, VISIBLE FROM SPACE, (2010).

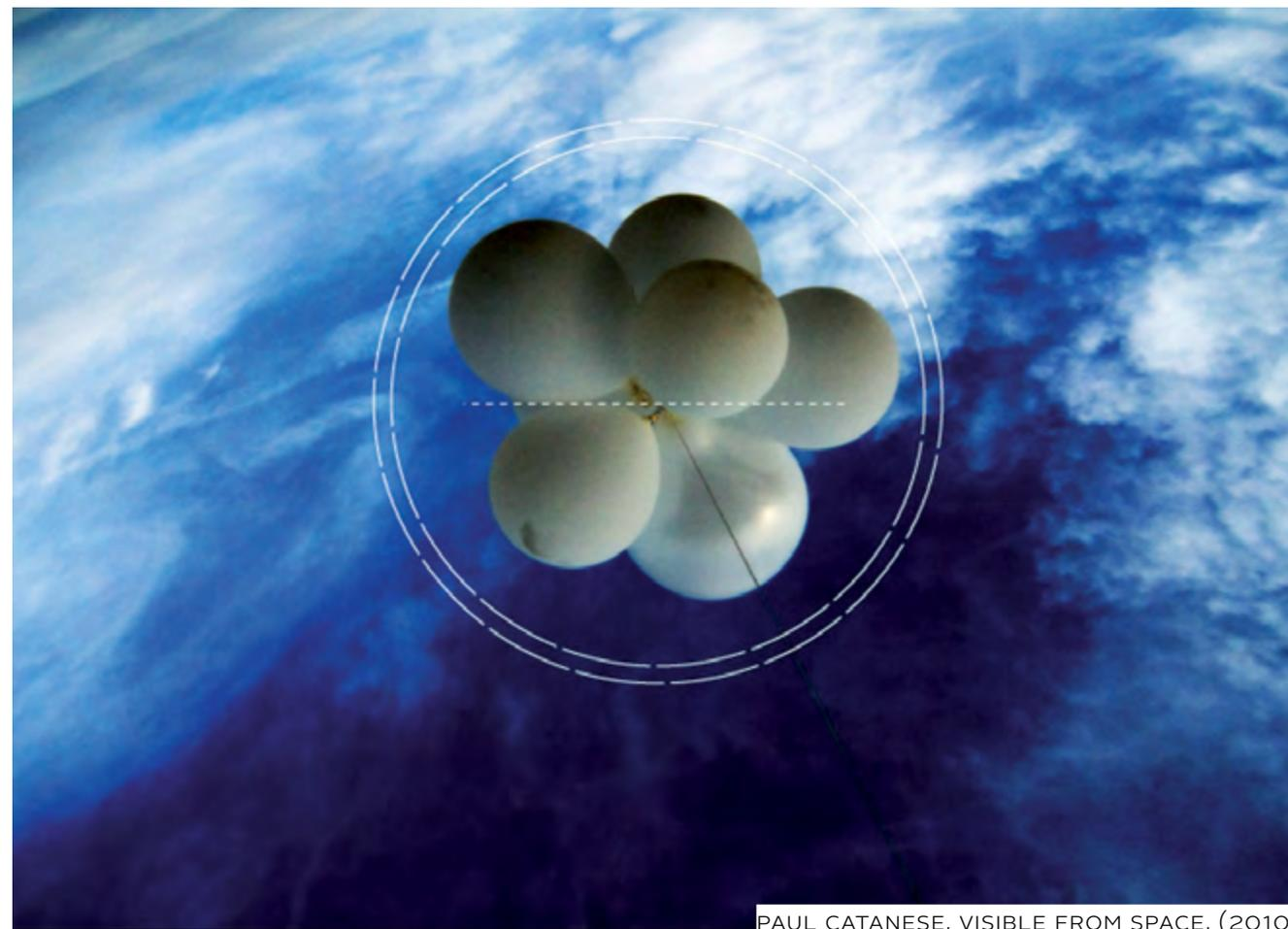
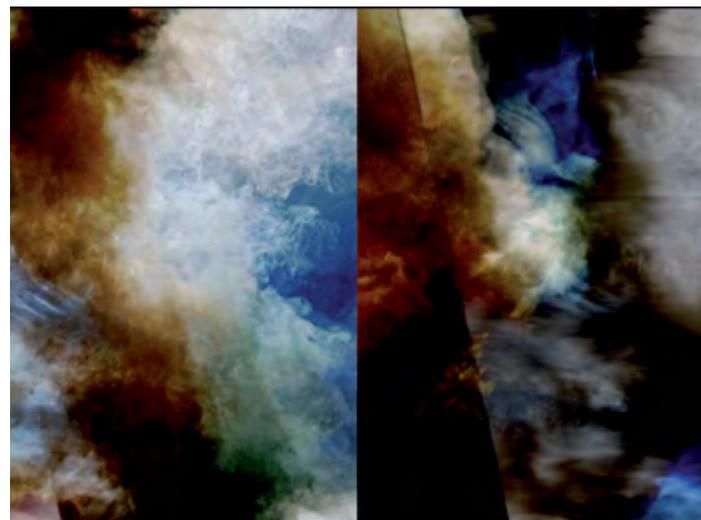

PAUL CATANESE, VISIBLE FROM SPACE, (2010).

# Interview with Paul Catanese, “Visible From Space” by Lanfranco Aceti and Vince Dziekan

Interview with artist Paul Catanese initially conducted via Flickr and coinciding with second half of ‘Visible From Space’ –the inaugural online exhibition with Leonardo Electronic Almanac in September 2010.

Lea

## Leonarda Electronic Almanac

We have just reached the half-way point in the release of Paul Catanese’s “Visible from Space”: the inaugural project of LEA’s new exhibition programme. If you’ve been following the progressive release of Paul’s images across our social media platforms (Facebook, Twitter and –of course– Flickr), you will no doubt have been struck by the work’s evolving character. To date, the release of an image-per-day has been accompanied by a very direct textual attribution, which reads as follows:

“Visible from Space” by Paul Catanese. Research and development for “Visible from Space” was supported by a month-long residency in June 2010 at the Goldwell Open Air Museum, just outside of Death Valley.

Over the remainder of the month, we will be using Flickr to host a conversation with Paul to tease out some of the ideas that are being alluded to through his images. Paul has provided the following artist statement –which, as one would expect, reads as intriguingly as his image-making –to initiate this process:

“The desert is a site of remote testing where paraconsistent logics are first considered feasible. Mistakenly construed as the opposite of the ocean, the desert teems with depth –it is also its own mirror.

I am conducting a thought experiment about the phrase ‘visible from space’ which erupted from a fanciful supposition to create drawings on the Earth so large they would be visible from the moon. For such a feat, the stroke width of the line would need to be close to 60 miles wide in order for barely a hairline to be visible from that distance. It is charming to think that the Great Wall of China is visible from space –but this is merely a popular mythology. It is difficult to resolve an image of the Great Wall even from the International Space Station with the naked eye –which orbits about 250 miles above the Earth, let alone from outer space or nearby celestial bodies. Of course, with military and even civilian imaging technologies, much greater resolution can be achieved as evidenced by what are now commonplace tools such as Google Earth.

Simultaneously –I have been thinking about the L’Arbre du Tenere –a lone tree that lived in the Saharan desert in Niger, the last of a stand of ancient acacias desperately isolated in an encroaching hostile landscape.

The ancient tree was well known as a caravan route marker and can be found as a single tree marked on maps in the middle of the vast desert. Oddly, this lone and ancient tree which shirked the reality of the desert met with its end after a truck driver ran into it in 1973. That lone tree of the desert, an odd single blip on the map –much like our geosynchronous satellites, occupies less than a pixels resolution worth of expanse when viewed from a distance.

While it is significant that we are able to achieve these feats, modern satellite imaging and a proposal to create a drawing on the Earth so large it that could be seen from the moon are similar in the fact that both actions require a wealth of engineering and a lack of humility. Viewed in this light, the requirements for surrogate vision depend on how we define visible, and where we define space. As I contemplate these requirements, I am reminded of L’Arbre Du Tenere, whose monument: a large metal sculpture of a tree –is not even the corpse of a tree”.



## Vince Dziekan

Hi Paul –Firstly congratulations on the project and in being so amenable to participating in this inaugural launch. As such, your work has been a real “test site” for LEA’s new exhibition platform. I’m wondering if you might like to start by giving us a bit of background about the site that you are responding to in this work (namely, Death Valley and in particular the Goldwell Open Air Museum)?

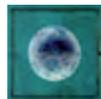

### Paul Catanese

Thanks, Vince –this is definitely an interesting format; I was very intrigued when approached regarding how a series of 30 (or 28 or 31!) images would be released one-a-day, glad to be part of the inaugural launch...

In terms of the site of Death Valley, and the Goldwell Open Air Museum –its an interesting place with a lot of history. Goldwell sits at the head of the Amargosa Valley in western Nevada. Its at about 3000' in elevation, and the valley is several dozen miles long. From the residency site –a former mining barn– you can watch storms roll in for hours. There's a sculpture park, and its also the site of a few ghost towns: Rhyolite has a number of standing masonry structures and is just behind the barn, and the Barn itself is essentially right on top of the site of the town of Bullfrog (named for a spectacular green mineral all through the area) –the only things left of Bullfrog are half of a jail, 1/8 of an icehouse, and tens of thousands of rusting cans. Just behind the barn are a few very steep mountains, but they've all been open-pit mined... to the east and south are huge tailings. It gets incredibly dark –the milky way is clearly visible, and the glow from Vegas, about 90 miles away, is the only urban light pollution you'll find. Its also important to note that the Nevada Test site is about 20 miles east (also east, Area 51 about 50 miles as the crow flies), and Death Valley just over the western ridge-line –about 6 miles. I specifically wanted to work out there in the summer, in the hot month of June, when temperatures can soar –and did! What I was perhaps the most stunned by, more than the rugged geography, high temperatures, or vastness of the chemical desert –was the silence. I mean stretches of silence where you might hear a fly buzzing 10 or 12 meters away. For this thought experiment, it was critical to be located where my activities would be no more contradictory than any other activities in a desert –but the silence provided a dimension of retreat that I did not anticipate.

I am stunned by the natural beauty and vastness of the land. Immediately I noticed the silence; a quietness that I found intensely refreshing that allowed me to truly get into my head and observe the world and my thoughts in it. I often found my eyes stunned by the landscape –how quickly it could change, how dunes could disappear into haze, or mountains seemingly flattened, erupt with great sculptural form and drama under the shadow of clouds. Death Valley itself was much more varied than I anticipated; I began understanding the location less as a singularity, and more as a unique component of a larger system of valleys, of north/south mountain ranges, of rift after rift. in spite of a veneer of desolation, everything seems to have been tread upon, touched, turned, tunneled through.

I learned about my companions: the Silver Cholla and the Desert Mallow, about how delicious the first morning light is on the valley, how my methods of collection and observation via the overhead projector were at home in the harsh environment, and how the exploration of space yields results that are puzzling. Goldwell was most definitely the correct location –of that, I am certain. Needless to say, it was a very good place to work.



### Vince Dziekan

You speak of being struck by the incredible depth of darkness and the unexpected dimension of silence. These descriptions beautifully resonate with the opening passage of your artist's statement, where you mention paraconsistent logics (that being, to attempt to deal with contradictions in a logical and systematic way). I see this reflected in the images you've produced.

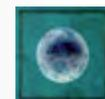

### Paul Catanese

Yes –building systems is a large part of my work, and definitely a large part about how I approached working on this exhibition for LEA. As soon as I started thinking about the “30-ness” of the series, I wanted to determine what the best structures were that would resonate with the details in the images. In this work, I am exploring multiple open-ended visual narratives and there were questions about whether the 30 in the series would be linear, chronological, or as it ended up, structured in a less-definable manner. I kept thinking about series of 5 and series of 6, or twinned series –a series of 5 running through a series of 6, or perhaps if one was to imagine two rectangles partially intersecting, there might be an area where a series of 3 and a series of 4 could fit into a meta-series of 5, and another that fits into a meta-series of 6.

I was playing games with the alphabet and with altered alphabets to assist me with determining how to arrange time and space. This type of game-playing with structure is creative exercise; its a way to assist me in viewing the materials from the desert in new ways. Beyond the meta-structures, what guided me in creating this series of images were a number of considerations regarding the notion of directionality of time, bifurcation, optics and gravity, as well as less determinable concepts such as asemic writing, ceromancy, and Otto's notion of the numinous.



### Vince Dziekan

The desert has an incredibly long tradition as a subject which has lent itself to the widest range of interpretations. Mystical. Sacred. Allegorical. Moral. Romantic. In a sense, the depth, richness and variability of these different interpretations play themselves out in stark relief against the desert's unifying visual emptiness. While the aesthetics are markedly different, I'm drawn to compare your project with America photographer Richard Misrach's desert 'cantos' –which also employ rigorous structural principles. Through an ironic counterpoising of form and content, the impossibly beautiful mirage-like surface of Misrach's photographs contemplate the transformation of the desert from sublime into a site that reflects militarism and environmental violence. The desert offers itself as something of a blank canvas, a surface that we –individually or collectively– can project our imagination and fears, desires and paranoias onto. Through your process, I'm wondering what the desert has revealed to you?



### Paul Catanese

The Revelation of the Desert. If one were to attribute agency to the land; the will of the desert could be encapsulated in its attempt to harm. The relentlessness of the land itself, the chemical desert, alluvial fans, calcrete, dust, desiccation, and solitude might first indicate a depth of fatality. But this is only a veneer. Rivers flow underground. Like the ocean, it teems with life; it is a site for contemplating the finite and the infinite.

The desert puzzles me. Every moment, the challenge of survival must be considered. It makes immediate the relation to the body, and therefore the mind. Synapses sizzle like ink on a brayer, the nervous system floods the ears with a high pitched whine that modulates the wind. Dust devils travel in packs, roam the valleys, rearranging bric-a-brac.

The desert can yawn for a thousand years.

We've talked of my experiences, and they remain distilled in me: Dry heat. Silence. Darkness. The Milky Way. Discerning the sound of a fly 30 feet away from me, crystal clear. Sunrise on the valley floor. Toads, rattle-snakes. Hydrating. Long, slow hikes through rubbish. Rabbits. Early Dawns. Rattling roof. Dust devils that chase me up into the barn and throw my supplies in a heap. The lingering odor of helium and latex. Time to think. Drawing for hours and hours until I passed out with my pen in my hand. Getting dizzy and telling myself to

get out of the sun. Fighter jets buzzing by a few dozen feet above me as I drove north up the Panamint valley. Trona. Man-made rubies. The wind blowing from every direction at once. Mercury. The white scar on the rocks at the southern end of the valley just south of the Amargosa farming area turnoff towards Shoshone, gleaming from miles away. Searching for seafoam green chips of gravel for hours. Listening.

I appreciate the reference to Misrach; the canto is an appropriate structure to respond to the richness and paradox of the desert, which is hidden. It reminds me of the cowboys and ranchers that I met. Intimately engaged with the land, they do not willingly seek out the taxonomies of science. Desert nomenclature is colloquial; mountains have personalities, with names like Charley or Wayne, who are putting on grey hair when its cold, even in the summer; the valley is a familiar who wears a pretty spring dress.



### Vince Dziekan

I really like the anecdote about desert colloquialism, so I might seize on this to take us back to the visual personality of the images you've crafted. Can you speak some more about their highly poetic vernacular and how asemic writing –which you mentioned earlier –relates to some of the concepts you are exploring in your work?



### Paul Catanese

With regard to asemic writing, on the one hand, it was something I was most specifically thinking about with regard to the unique venue for the release of the image. I decided from the beginning that any of the images should be able to function as a starting point; and though there are certain irreversible concepts present, traversing the multiple visual narratives should be possible whether perusing forwards or backwards. So, partially, the poetics of the image you're responding to are my approach towards composition, space, and narrative –but also my decision to particularly consider the idea of two twinned series that might occasionally take place simultaneously. Bifurcation followed backwards; ballistics frozen; helium trapped in the membrane of an image. In several cases throughout the series, the images reference events and experiments I conducted during my stay in the desert, working with rockets, helium balloons, windsocks, smoke, dust, mirror, lasers, wireless and

infrared cameras, as well as found objects: natural and manufactured. Some of these references are photographic; others are culled directly from my sketches and field notes. There is no division between notes describing planning, simulation of experiments, or field notes describing results. But perhaps more specifically, visual signifiers of scientific quantification or accumulation such as diagrams, graphs, and charts, detached from the context in which they were produced, begin to nod toward the asemic. These forms of message are a central feature in much of my work –both in the planning and performance. The rupture between communication encoded and message received provides a playful disruption in the language of narrative.

The colloquialism of the desert is omnipresent; between the detritus of human encampment, the violence of mining debris, overt military training stretched thin around forbidden Tarkovsky-esque zones, rangers struggling with tourists, scorpions, and crashed Cessna's, thirsty geologists, bordellos, experimental automotive test teams, ranchers –nothing is entirely familiar– and that which is recognizable, assumes new meanings, becomes less of a solid.



#### Lanfranco Aceti

I would like to actually continue along the line of this topic that you and Vince have been discussing –the relationship with the landscape as a complex interaction beyond the anthropocentric definition of psycho-geography and traditional representations of alterity. I am curious to know how you framed your relationship to the 'intuitive' and 'aesthetic' colloquialism with the desert... Was it a planned structure –or something that you just let flourish inspired by the pre-existing discourse and already existing semiotic signs of the landscape?

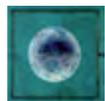

#### Paul Catanese

Hi Lanfranco –this is an interesting question. I've been thinking quite a bit about this, especially as I have come to find that residencies are an important part of my art practice, playing a valuable role, especially in providing time to insert oneself in a new context. It is often very tempting to plan, or even perhaps over-plan the experience. That being said, it has continually been the organic development of ideas that indeed flourish within a given space or location that are the most rewarding for me as an artist.

So, to a certain degree, I did spend a great deal of time planning for my experiments with rockets, balloons, cameras, etc. but I had not entirely considered the role that desert colloquialism would have. This is largely due to the fact that I wasn't entirely certain how much interaction with other individuals I would have. At first, I had visions of being entirely cut off from the world, but as it turned out, the human connections at the residency and at the town where I was staying began to play a pivotal role in providing a more tempered experience. I

did imagine that there would be aspects of living in the desert that would be unexpected that would shift the focus or dimensions of experiments, but had not considered that would erupt from human interaction.

It is possible to consider the harshness of the chemical desert and then view that harshness amplified and compounded by secrecy, industrialism, and paranoia and expect that those characteristics to be the only fruit of the vastness. Earlier, when Vince referred to the notion of the desert as a blank canvas, a surface for projection (literally and conceptually), I recognized that attuning my body and mind to the rhythms of living at that location are as much a part of the work as the images themselves.

I was at Goldwell long enough to begin to acclimate to the remoteness of the location. There was a general store, gas station, a lunch counter, a saloon, and very little else. When the groceries ran out on Monday, you would have to wait until the truck showed up on Wednesday –or drive ninety miles to the next closest supplies. In attuning to these new rhythms, I began to find that there is a relativism to remoteness. On excursions from the home base of the residency into the wilderness of the Amargosa, Death and Panamint Valleys, which lie parallel to one another; the outline of familiar mountains and dunes provided much more than way-finding, but rather, an unexpected sentiment: comfort.

Perhaps it is the immediacy of mortal danger, where preparing for scenarios like a flat tire, or running low on water, that would otherwise be inconveniences, is what heightens the sense of ease that comes with approaching the familiar: a particular stand of bushes, riparian glade, or even a bundle of fencing, tailings, or shift from sand to gravel roads. After a while, it seems reasonable to provide these physical features with nicknames and epithet, since it is appealing to pretend that they are in some manner benevolent.



#### Lanfranco Aceti

My next question is on the importance of the traditional concept of residency and its relationship to space. One of the aspects of contemporary art (in new media or other platforms) is that of revealing new concepts and challenging old assumptions based on new interpretations and engagements with the space. Do you believe that there is a space for 'virtual residencies' and what could be the frameworks that are most suitable to contemporary artistic practices?

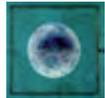

### Paul Catanese

My residency experiences have focused on a break from the everyday, while simultaneously engaging with new individuals, sites, and technologies. Embodiment of the unfamiliar coupled with a self-induced rupture from routines, and the subsequent reflection on my reaction to the reorganization of my working processes is at the core of what I am seeking from a residency experience. Immersion is key. I want to learn things that I had not planned to learn, and physical relocation intrinsically catalyzes these types of experiences.

I do believe that 'virtual residencies' have a role to play and are absolutely capable with regard to challenging assumptions of space and inducing ruptures that encourage meta-reflection. In terms of what frameworks are suitable –I wonder if one pre-requisite could be to invite individuals who are in transit/traveling to simultaneously be in a virtual residency. I've often thought it would be interesting to participate in a residency program that funds individuals to travel somewhere and report back on what they find. Perhaps if this were coupled with a virtual residency, the role of the resident shifts. Where the experience of the residency tends to solely be first-person, perhaps it could be used to additionally provide a third-person view for everyone else. Of

course, at this point, I've essentially re-invented non-virtual residencies to take on virtual components –and it sounds suspiciously like a travelogue.

I find the conversation we're having contains elements of 'virtual residency' that are valuable. Participating in a discussion over an extended period of time with individuals who are in Australia and Turkey, while I'm here in Chicago has been rewarding, and in itself functions as a way of reflecting on the experiences of the desert. Our conversation is more critical and probing, since in the desert, it was mostly about experimentation, drawing, and survival, whereas we are almost entirely focused on the analyzing that experience. The framework reminds me somewhat of what is successful about the asynchronous discussions on Empyre. It could also be interesting to embrace the notion of conversation in dislocated space such as in 'this spartan life' or even 'sleep is death' –where virtual space functions as a location for conversation. That being said, I'll admit, I'd prefer if I also were able to walk around Istanbul or Melbourne as part of our conversation, where I might have the feeling of being out of my element, or was able to share a cup of tea with each of you.

**KASA GALERİ**

**E-scapes**  
Artistic Explorations of Nature and Science

February 1  
March 1  
2012

**Paul Catanese**  
**Jane Prophet**

**KASA GALERİ**  
DIRECTOR LANFRANCO ACETI  
VICE DIRECTOR AND IN HOUSE CURATOR ÖZDEN SAHİN  
ADJUNCT CURATOR VINCE DZIEKAN

"E-SCAPES: ARTISTIC EXPLORATIONS OF NATURE AND SCIENCE"  
Paul Catanese "Visible From Space"  
Jane Prophet "Explorations Of Structure"

Sabancı Üniversitesi | L'Es | Goldsmiths

**KASA GALERİ 2012 / 'E-SCAPES: ARTISTIC EXPLORATIONS OF NATURE AND SCIENCE' | JANE PROPHET & PAUL CATANESE**  
1 ŞUBAT-1 MART 2012

**KASA GALERİ** | Bankalar Caddesi 2, Karaköy, 34420 İstanbul  
T (0212) 292 49 39  
kasagaleri.sabanciuniv.edu

KASA GALERİ

'E-SCAPES: ARTISTIC EXPLORATIONS OF NATURE AND SCIENCE' | JANE PROPHET & PAUL CATANESE  
FEBRUARY 1<sup>ST</sup>-MARCH 1<sup>ST</sup> 2012

"THE DESERT IS A SITE OF REMOTE TESTING WHERE PARACONSISTENT LOGICS ARE FIRST CONSIDERED FEASIBLE. MISTAKENLY CONSTRUED AS THE OPPOSITE OF THE OCEAN, THE DESERT TEEMS WITH DEPTH -IT IS ALSO ITS OWN MIRROR."

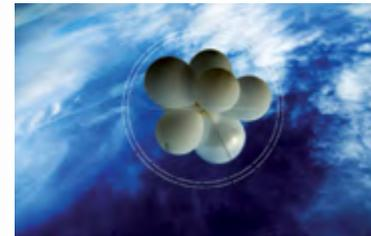

Paul Catanese's 'Visible from Space' is a fanciful supposition to create drawings on the Earth so large they would be visible from the moon. The artworks were inspired by L'Arbre du Tenere -a lone and ancient acacias tree that lived in the hostile landscape of Saharan desert in Niger. That route marker of the desert, an odd single blip on the map -much like our geosynchronous satellites, occupies less than a pixels resolution worth of expanse when viewed from a distance.

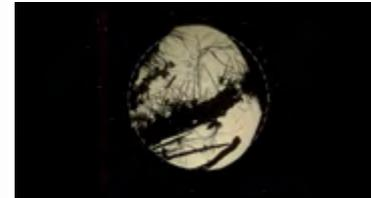

Jane Prophet's "Explorations of Structure" uses innovative media combined with a traditional aesthetics to explore landscape design, object and physical presence. What is a non-place? Something that exists only in the imagination? A place forever lost? In this portfolio of images Jane Prophet takes previously completed art works and re-evaluates them as explorations of structure that reveal the treatment of politics of landscape in the form of a variety of visual representations, as well as elements derived from fractal mathematics.



"THE LANDSCAPE THEME IS VERY MUCH ABOUT EXPOSING HOW 'CONSTRUCTED' SO-CALLED UTOPIAN OR SUBLIME EXPERIENCES OF NATURE ARE."

**About Paul Catanese**

Paul Catanese is a hybrid media artist, Associate Chair and Associate Professor in the Department of Interdisciplinary Arts at Columbia College Chicago and the President of the New Media Caucus, a College Art Association Affiliate Society. His artwork has been exhibited widely including at the Whitney Museum of American Art, the New Museum of Contemporary Art, SFMOMA Artist's Gallery, La Villette-Numerique and Stuttgarter Filmwinter among others. Paul is the recipient of numerous grants and awards, including commissions for the creation of new artwork from Turbulence.org as well as Rhizome.org.

**About Jane Prophet**

Jane Prophet is Professor of Art and Interdisciplinary Computing at Goldsmiths College. Her research interests span Art, Computer Science, Digital Humanities and Technology. Recent works include *The Withdrawing Room*, a series of laser cut dictionaries for Samuel Johnson's *House* (2009); *(Trans)Plant*, 2008, a kinetic aluminum sculpture based on the structure of a plant; *Counterbalance*, 2007, a light based installation commissioned for a flood plain in Australia and *Souvenir of England*, 2007, a preserved apple tree covered in black velvet flocking and displayed in a giant snow dome. She works in London and the US east coast, where she has recently relocated her studio.

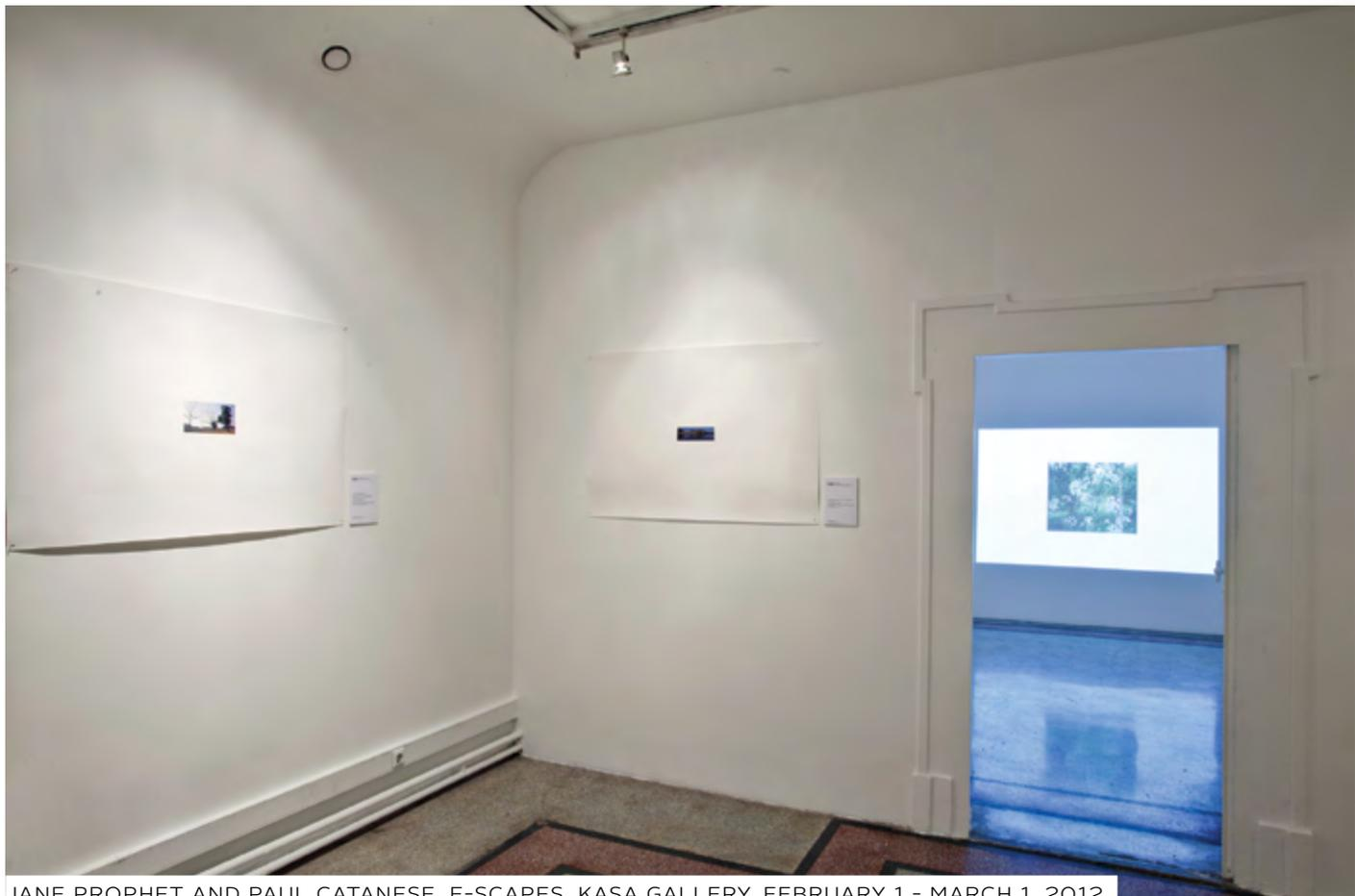

JANE PROPHET AND PAUL CATANESE, E-SCAPES, KASA GALLERY, FEBRUARY 1 - MARCH 1, 2012.  
(PHOTOGRAPHIC DOCUMENTATION BY KORHAN KARAOYSAL.)



JANE PROPHET AND PAUL CATANESE, E-SCAPES, KASA GALLERY, FEBRUARY 1 - MARCH 1, 2012.  
(PHOTOGRAPHIC DOCUMENTATION BY KORHAN KARAOYSAL.)



JANE PROPHET AND PAUL CATANESE, E-SCAPES, KASA GALLERY, FEBRUARY 1 - MARCH 1, 2012.  
(PHOTOGRAPHIC DOCUMENTATION BY KORHAN KARAOYSAL.)



JANE PROPHET AND PAUL CATANESE, E-SCAPES, KASA GALLERY, FEBRUARY 1 - MARCH 1, 2012.  
(PHOTOGRAPHIC DOCUMENTATION BY KORHAN KARAOYSAL.)



JANE PROPHET AND PAUL CATANESE, E-SCAPES, KASA GALLERY, FEBRUARY 1 - MARCH 1, 2012.  
(PHOTOGRAPHIC DOCUMENTATION BY KORHAN KARAOYSAL.)



JANE PROPHET AND PAUL CATANESE, E-SCAPES, KASA GALLERY, FEBRUARY 1 - MARCH 1, 2012.  
 (PHOTOGRAPHIC DOCUMENTATION BY KORHAN KARAOYSAL.)



JANE PROPHET AND PAUL CATANESE, E-SCAPES, KASA GALLERY,  
 FEBRUARY 1 - MARCH 1, 2012. (PHOTOGRAPHIC DOCUMENTATION BY KORHAN  
 KARAOYSAL.)



JANE PROPHET AND PAUL CATANESE, E-SCAPES, KASA GALLERY, FEBRUARY 1 - MARCH 1, 2012.  
(PHOTOGRAPHIC DOCUMENTATION BY KORHAN KARAOYSAL.)



JANE PROPHET AND PAUL CATANESE, E-SCAPES, KASA GALLERY, FEBRUARY 1 - MARCH 1, 2012.  
(PHOTOGRAPHIC DOCUMENTATION BY KORHAN KARAOYSAL.)



JANE PROPHET AND PAUL CATANESE, E-SCAPES, KASA GALLERY, FEBRUARY 1 - MARCH 1, 2012. (PHOTOGRAPHIC DOCUMENTATION BY KORHAN KARAOYSAL.)

